

**Programme**  
**Book of Abstracts**

**11<sup>th</sup> IAEA Technical Meeting on  
Control, Data Acquisition, and Remote  
Participation for Fusion Research**

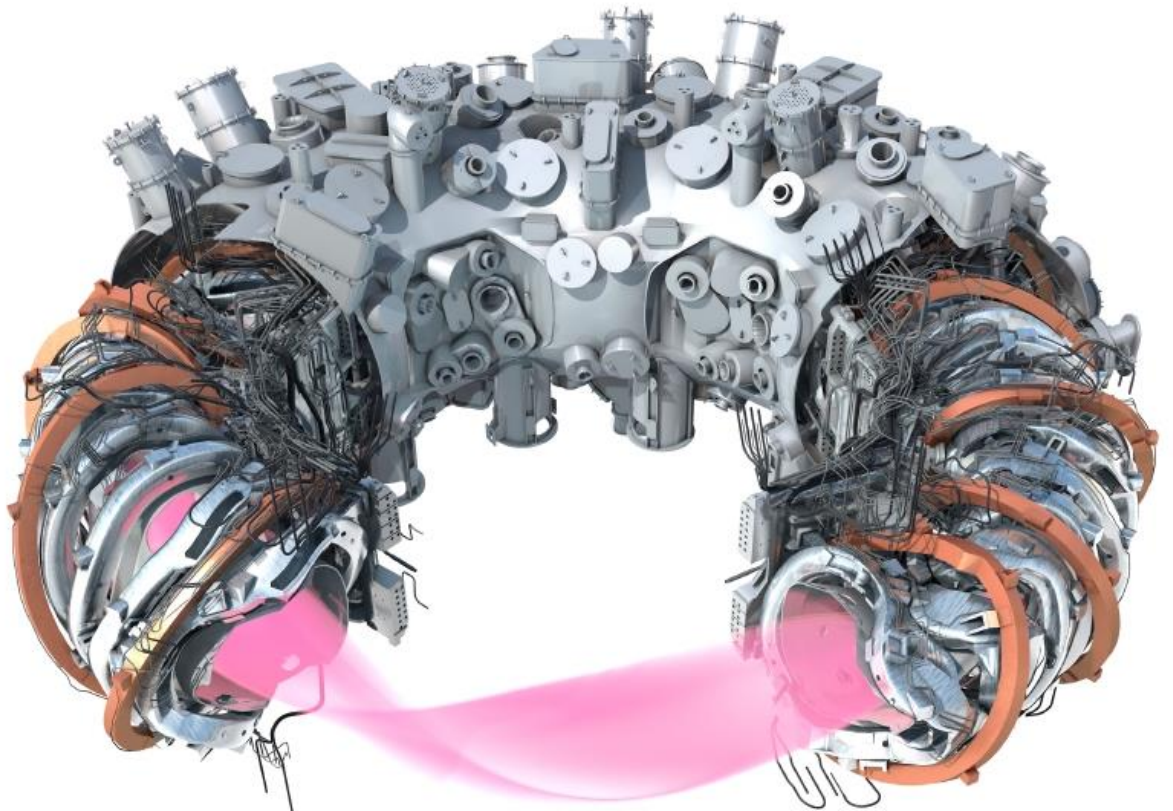

**Greifswald, Germany**

**8 – 12 May 2017**

**DISCLAIMER:**

*This is not an official IAEA publication. The views expressed do not necessarily reflect those of the International Atomic Energy Agency or its Member States.*

*The material has not undergone an official review by the IAEA. This document should not be quoted or listed as a reference.*

*The use of particular designations of countries or territories does not imply any judgement by the IAEA, as to the legal status of such countries or territories, of their authorities and institutions or of the delimitation of their boundaries.*

*The mention of names of specific companies or products (whether or not indicated as registered) does not imply any intention to infringe proprietary rights, nor should it be construed as an endorsement or recommendation on the part of the IAEA.*

# **11<sup>th</sup> IAEA Technical Meeting on Control, Data Acquisition, and Remote Participation for Fusion Research**

**8 -12 May, 2017**

**Greifswald, Germany**

## **IAEA Scientific Secretary**

Ms. Sehila Maria Gonzalez de Vicente

**International Atomic Energy Agency**

Vienna International Centre

Wagramer Straße 5, PO Box 100

A-1400 Vienna, Austria

NAPC Physics Section

Tel: +43-1-2600-21753

Fax: +43-1-26007

E-mail: [Physics@iaea.org](mailto:Physics@iaea.org)

## **International Programme Advisory Committee**

Chair: K. Behler (Germany)

H.-S. Bosch (Germany), S.-H. Hahn (Korea), A. Luchetta (Italy), H. Nakanishi (Japan), W. Pires De Sá (Brazil), H. Pujara (India), N. Ravenel (France), D. Schissel (USA), J. Stillerman (USA), J. Waterhouse (United Kingdom), A. Winter (ITER), B. Xiao (China)

## **Local Organisation Committee**

Chair of LOC Greifswald: H.-S. Bosch

Conference Secretary: M. Papenhagen

Max-Planck-Institut für Plasmaphysik,

Greifswald, Germany

Phone: +49 3834 88-2000

Fax: +49 3834 88-2709

e-mail: [iaeatm2017@ipp.mpg.de](mailto:iaeatm2017@ipp.mpg.de)

## **Meeting Website:**

<https://nucleus.iaea.org/sites/fusionportal/Pages/List-of-TMs-on-RUSFD.aspx>

<http://www.ipp.mpg.de/iaeatm2017>

## Topics

- I. Plasma Control;**
- II. Machine Control, Monitoring, Safety and Remote Manipulation;**
- III. Data Acquisition and Signal Processing;**
- IV. Database Techniques for Information Storage and Retrieval;**
- V. Advanced Computing and Massive Data Analysis;**
- VI. Remote Participation and Virtual Laboratory;**
- VII. Fast Network Technology and its Application.**

## Schedule

**Monday, 8 May, 2017**

7:45	<b>Bus to IPP</b>
8:00-9:00	<b>Registration</b>
9:00-9:20	<b>Welcome and Opening Address</b>
<b>Session S1.S: Plasma Control Systems</b> Chair: Bosch H.-S.	
9:20-10:00	<b>I-1:</b> Werner A. <i>Commissioning and Operation of the Wendelstein 7-X Steady State Data Acquisition and Control System</i>
10:00-10:20	<b>O-1:</b> Hasegawa M. <i>Modifications of Plasma Control System and Central Control System for Integrated Control of Long Plasma Sustainment on QUEST</i>
10:20-10:40	<b>O-2:</b> Asenjo J. <i>Control and Data Acquisition System for SCR-1 Stellarator</i>
10:40-11:10	<b>Coffee Break</b>
<b>Session S1.S: Plasma Control Systems</b> Chair: Nakanishi H.	
11:10-11:30	<b>O-3:</b> Xiao B.J. <i>Integrated Plasma Control for Long Pulse Advanced Plasma Discharges on EAST Kicks on TCV</i>
11:30-11:50	<b>O-4:</b> Lee W. <i>New Control Systems at KSTAR Compatible with ITER Standard Technologies</i>
11:50-12:10	<b>O-5:</b> Ravenel N. on behalf of Colnel J. <i>Adapting DCS Real Time Framework for WEST PCS</i>
12:10-12:30	<b>O-6:</b> Santraine B. <i>Status of the CODAC System for WEST</i>
12:30-13:30	<b>Lunch Break</b>

<b>Session S2: Machine Control</b> <b>Chair: Winter A.</b>	
13:30-13:50	<b>O-7:</b> Tak T. <i>Conceptual Design of New Data Integration and Process System for KSTAR Pulse and Data Scheduling</i>
13:50-14:10	<b>O-8:</b> Spring A. <i>Plugging Physics into the W7-X CoDaC Framework</i>
14:10-14:30	<b>O-9:</b> Nakanishi H. <i>Integrated Radiation Monitoring and Interlock System for the LHD Deuterium Experiments</i>
14:30-14:50	<b>O-10:</b> Luchetta A. <i>Instrumentation and Control for the Neutral Beam Test Facility</i>
14:50-15:20	<b>Coffee Break</b>
<b>Session S2.I: ITER Machine Control</b> <b>Chair: Xiao B.</b>	
15:20-15:40	<b>O-11:</b> Winter A. <i>The ITER Real-Time Framework Final Design</i>
15:40-16:00	<b>O-12:</b> Pedica R. on behalf of Fernández-Hernando J.L. <i>The ITER Interlock System</i>
16:00-16:20	<b>O-13:</b> Davis W. <i>Integration of Electrical Networks I&amp;C to ITER CODAC</i>
16:20-16:40	<b>O-14:</b> Prokopas M. <i>ITER Control System Model: A Full-Scale Simulation Platform for the CODAC Infrastructure</i>
16:40-17:45	<b>Bosch H.S.</b> <i>W7-X Machine Overview</i>
17:45-18:45	<b>W7-X Tour</b> (4 groups)
19:00-21:30	<b>Welcome Reception (IPP)</b>
21:30	<b>Bus to Hotel</b>

## Tuesday, 9 May, 2017

8:30

**Bus to IPP**

### Session S1: Plasma Control Chair: Nakanishi H.

9:00-9:25	<b>O-15:</b> Cruz N. <i>On the Control System Preparation for Experiments on ELM Pacing with Vertical</i>
9:25-9:50	<b>O-16:</b> Walker M.L., <i>Enabling Co-Simulation of a Tokamak Plant Model and Plasma Control System</i>
9:50-10:30	<b>I-2:</b> Eldon D. <i>Divertor Control Development at DIII-D and Implications for ITER</i>

10:30-11:00

**Coffee Break**

### Session S1.I: ITER Plasma Control Chair: Winter A.

11:00-11:25	<b>O-17:</b> Snipes J.A. <i>The Preliminary Design of the ITER Plasma Control System</i>
11:25-11:50	<b>O-18:</b> Treutterer W. <i>The Preliminary Architectural Design of the ITER Plasma Control System</i>
11:50-12:10	<b>O-19:</b> Raupp G. <i>Exception Handling in the Preliminary Design of the ITER Plasma Control</i>
12:10-12:30	<b>O-20:</b> De Vries P.C. <i>Preparing the PCS final design for ITER first plasma</i>

12:30-13:15

**Lunch Break**

### Session S1.A: Plasma Control Algorithms Chair: Luchetta A.

13:15-13:35	<b>O-21:</b> Miyata Y. <i>Investigation of Methods for Mitigating Influences of Magnetic Measurement Noises on Equilibrium Control in JT-60SA</i>
13:35-13:55	<b>O-22:</b> Hu F. <i>Implementation of the On-line Density Limit Disruptions Prediction and Avoidance System Based on Neural Networks</i>
13:55-14:15	<b>O-23:</b> Joung S., <i>Neural Network Based Real-Time Reconstruction of KSTAR Magnetic Equilibrium and Imputation with Bayesian Scheme</i>
14:15-14:45	<b>O-24:</b> Clement M., <i>GPU Based Optimal Control Techniques for Resistive Wall Mode (RWM) Feedback in Tokamaks</i>

14:45-15:00	<b>Coffee Break</b>
15:00-18:00	<b>Poster Session 1</b> <ul style="list-style-type: none"> <li>• Control Systems</li> <li>• Plasma Control</li> <li>• Machine Control</li> </ul>
18:00	<b>Bus to Hotel</b>

## Wednesday, 10 May, 2017

8:30	<b>Bus to IPP</b>
<b>Session S3: DAQ &amp; Analysis</b> <b>Chair: Behler K.</b>	
9:00-9:15	<b>O-25:</b> Dreval M.B. <i>Microprocessor-Based Digitizers Combined with Preamplifiers and Detectors as a Solution for EMI Suppression in U-3M</i>
9:15-9:30	<b>O-26:</b> Semenov I. <i>Online Processing of Large Volume Experimental Data in Strong Electromagnetic and Radiation Fields in ITER Neutron Diagnostics</i>
9:30-9:50	<b>O-27:</b> Taliercio C. <i>A Framework for the Integration of Linux FPGA SoC Devices</i>
9:50-10:30	<b>I-3:</b> Fischer R. <i>Integrated Data Analysis for Measurements in Fusion Devices - Concept and Applications</i>
10:30-11:00	<b>Coffee Break</b>
<b>Session S4: Storage</b> <b>Chair: Stillerman J.</b>	
11:00-11:20	<b>O-28:</b> Holtz A. <i>Continuous Acquisition and Storage of Wendelstein 7-X Data</i>
11:20-11:35	<b>O-29:</b> Dumke S. <i>Next Generation Web Based Live Data Monitoring for W7-X</i>
11:35-11:50	<b>O-30:</b> Wang F. <i>Study of Data Statistics and Retrieval for EAST MDSplus Data System</i>
11:50-12:10	<b>O-31:</b> Castro R. <i>ITER Unified Data Access (UDA)</i>
12:10-12:30	<b>O-32:</b> Piglowski D.A. <i>Evaluation of the ITER Data Archiving Network API on the DIII-D Tokamak</i>



12:30-13:30	<b>Lunch Break</b>
<b>Session S4: Storage</b> Chair: Schissel D.	
13:30-13:50	<b>O-33:</b> Fredian T. <i>MDSplus Yesterday, Today and Tomorrow</i>
13:50-14:05	<b>O-34:</b> Fridrich D. <i>Hierarchical Dynamic Containers for Fusion Data</i>
14:05-14:20	<b>O-35:</b> Zheng W. <i>Distributed Database based Data Storage and Manage System for Future Fusion Experiment</i>
14:20-14:40	<b>O-36:</b> Sammuli B.S. <i>TokSearch: A Search Engine for Fusion Experimental Data</i>
14:40-15:00	<b>O-37:</b> Stillerman J. <i>Navigational Data Management</i>
15:00-15:30	<b>Coffee Break</b>
16:00-18:30	<b>Poster Session 2</b> <ul style="list-style-type: none"> <li>• DAQ, Analysis</li> <li>• Storage</li> <li>• Remote Participation</li> <li>• Network Technology</li> </ul>
18:30	<b>Bus to Hotel</b>

## Thursday, 11 May, 2017

8:30	<b>Bus to IPP</b>
<b>Session S5: Advanced Computing</b> Chair: Ravenel N.	
9:00-9:20	<b>O-38:</b> Iannone F. <i>MARCONI FUSION: The new High Performance Computing Facility for European Nuclear Fusion Modeling</i>
9:20-9:40	<b>O-39:</b> Esquembri S. <i>Methodology for the Implementation of Real Time Image Processing Systems Using FPGAs and GPUs and Their Integration in EPICS Using Nominal Device Support</i>

<b>Session S6: Remote Participation</b> <b>Chair: Behler K.</b>	
9:40-10:00	<b>O-40:</b> Farthing J. <i>Status of ITER Remote Experimentation Centre</i>
10:00-10:20	<b>O-41:</b> Rigoni A. <i>Assessing Remote Data Access feasibility for the ITER Remote Experimentation Centre</i>
10:20-10:50	<b>Coffee Break</b>
10:50-11:10	<b>O-42:</b> Yamanaka K. <i>On-demand File Transfer for ITER Remote Experiments</i>
11:10-11:30	<b>O-43:</b> Schissel D.P. <i>Remote Operation of EAST</i>
<b>Session S7: Network Technology</b> <b>Chair: Waterhouse J.</b>	
11:30-11:50	<b>O-44:</b> Erickson K.G. <i>NSTX-U Advances in Real-time Deterministic PCIe-based Internode Communication</i>
11:50-12:10	<b>O-45:</b> Emoto M. <i>Inter-Application Communication during LHD Consecutive Short Pulse Discharge Experiment</i>
12:10-12:30	<b>O-46:</b> Kwon G. <i>Development Real-Time Data Archive System for KSTAR Real-Time Network</i>
12:30-13:30	<b>Lunch Break</b>
13:30-18:00	<b>Bus tour to Peenemünde</b>
18:00	<b>Conference Dinner (Wassermühle Hanshagen)</b>
21:30	<b>Bus to Hotel</b>

## Friday, 12 May, 2017

8:30	<b>Bus to IPP</b>
<b>Session MDSplus Chair: Manduchi G.</b>	
9:00-10:30	<b>MDS+ satellite-meeting</b>
10:00	<b>Bus to IPP</b>
10:30-11:00	<b>Coffee Break</b>
<b>Summary. Discussion Chair: Gonzalez De Vicente S.M.</b>	
11:00-11:30	<b>Summary</b>
11:30-12:00	<b>Discussion</b>
12:00-12:20	<b>Closing</b>
12:20-12:55	<b>Lunch Break</b>
12:55	<b>Bus to main station</b>

# Abstracts

## List of Invited Orals:

**I-1:** A. Werner, *Commissioning and Operation of the Wendelstein 7-X Steady State Data Acquisition and Control System*

**I-2:** D. Eldon, *Divertor Control Development at DIII-D and Implications for ITER*

**I-3:** R. Fischer, *Integrated Data Analysis for Measurements in Fusion Devices - Concept and Applications*

## **I-1: Commissioning and operation of the Wendelstein 7-X steady state data acquisition and control system**

Andreas Werner, Dieter Aßmus, Torsten Bluhm, Kirk Gallowski, Michael Grahl, Martin Grün, Uwe Herbst, Andreas Holtz, Cornelia Klug, Jon Krom, Georg Kühner, Heike Laqua, Marc Lewerentz, Mirko Marquardt, Andreas Möller, Ina Müller, Karsten Näckel, Heike Riemann, Steffen Pingel, Jörg Schacht, Anett Spring, Uwe Stridde, Svetlana Valet, Andreas Wölk, Manfred Zilker and the W7-X team

*Max-Planck-Institut für Plasmaphysik, Wendelsteinstraße 1, D-17491 Greifswald*

E-mail of Corresponding Author: [andreas.werner@ipp.mpg.de](mailto:andreas.werner@ipp.mpg.de)

Wendelstein 7-X has started its operation in December 2015 and the CoDaC system could deliver its services in a mature state, i.e. the system was fully operational over the campaign. The CoDaC system has a hierarchical control system with central safety system on top, the central operational management based on programmable logic controllers (PLC) for slow control and the fast plasma control system with VxWorks real time computers. The control systems as well as the data acquisition system and configuration control complete the control and data acquisition system, which is already designed and implemented for continuous operation.

The safety control system was the most time critical one and has been successfully inspected intensively by the technical supervision authority, in particular with respect to the radiation protection systems and personnel safety. The central operational system was put in operation for the subsystem communication, like e.g. the communication between cryostat instrumentation and cryo plant, as well as for supervision of the main systems like magnets, vacuum systems and gas warnings. Furthermore, this system organizes the subordination of the fast control stations into the experiment program. The central real time control system could be commissioned within three days. It could demonstrate its steady state capabilities by executing a 10 minutes experiment program with 10 ECRH short pulses included already in the first week of operation.

While the central systems have been commissioned shortly before the first experimental campaign, many subsystems were in operation already one year before. The data acquisition system acquired the PLC station data continuously for more than 2 years. For the experiment runs, first high performance data acquisition systems have been setup for continuous operation although the longest pulse was slightly above 6 seconds. All these so called data acquisition and fast control stations are programmed in the experiment editor and their configuration is managed via the central configuration database.

All these systems are managed from the control room, which is almost completely based on virtualization technologies and allows group forming at the workstations according to the experiment taskforces. Even the central video wall is driven via virtual computers and network connections, i.e. without any video cable connections.

## I-2: Divertor control development at DIII-D and implications for ITER

D. Eldon<sup>1</sup>, E. Kolemen<sup>2</sup>, A. W. Hyatt<sup>1</sup>, J. L. Barton<sup>3</sup>, A. R. Briesemeister<sup>4</sup>, N. Eidietis<sup>1</sup>, H. Y. Guo<sup>1</sup>, E. T. Hinson, D. A. Humphreys<sup>1</sup>, A. E. Järvinen<sup>5</sup>, A. W. Leonard<sup>1</sup>, A. G. McLean<sup>5</sup>, A. L. Moser<sup>1</sup>, T. W. Petrie<sup>1</sup>, B. Sammuli<sup>1</sup>, C. Samuel<sup>5</sup>, and M. L. Walker<sup>1</sup>

<sup>1</sup>General Atomics, PO Box 85608, San Diego, CA 92186-5608, USA

<sup>2</sup>Princeton University, Princeton, NJ 08543, USA

<sup>3</sup>Sandia National Laboratories, Livermore, CA 94550, USA

<sup>4</sup>Oak Ridge National Laboratory, Oak Ridge, TN 37831, USA

<sup>5</sup>Lawrence Livermore National Laboratory, PO Box 808, Livermore, CA 94550, USA

E-mail of Corresponding Author: [eldond@fusion.gat.com](mailto:eldond@fusion.gat.com)

DIII-D has demonstrated the ability to maintain fixed inter-ELM divertor  $T_e$  on either side of a sharp transition from high to low  $T_e$ , termed a “cliff”. Divertor  $T_e$  responds to changes in gas puff command on a  $\sim 100$  ms timescale, making this control appropriate for tracking changes in detachment onset density through evolutions like modulations of input power (DIII-D confinement time  $\sim 100$  ms) or impurity accumulation ( $\tau \gg 100$  ms). This control supports detachment studies by holding conditions at the cliff, resulting in many transitions from high to low  $T_e$ . The “hot” edge of the  $T_e$  cliff moves from 10 to 17 eV when  $N_2$  is puffed instead of  $D_2$

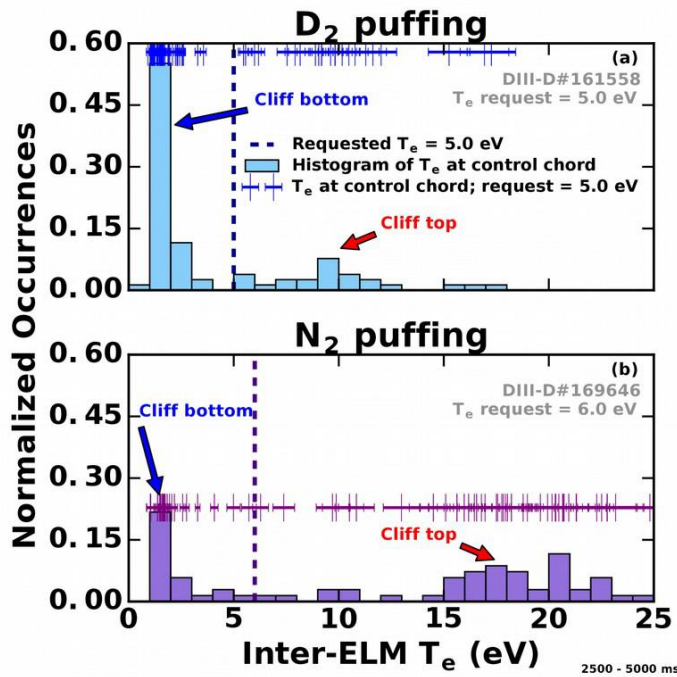

Figure 1: Differences in  $T_e$  cliff position between deuterium and nitrogen

(Fig. 1) and the pedestal  $n_e$  for detachment decreases from 9.1 to  $6.6 \times 10^{19}/m^3$ . Reduced density is beneficial, but higher  $T_e$  at the cliff top could translate to higher wear in ITER should detachment be lost. The divertor radiation control system is able to produce and regulate a requested value of local radiated power by puffing nitrogen into the divertor with relatively mild impact on the core plasma: static gain of local radiation vs. divertor gas puffing is 6 times higher in the divertor relative to the core. Improvements in strike point control enabled tests with the new Small Angle Slot (SAS) divertor installed at DIII-D with precision as tight as  $\pm 1$  mm outside of the influence of ELMs. This is important as the SAS is very sensitive to strike point position. Investigating these controls will help inform ITER’s heat load management strategies.

This work is supported by the U.S. Department of Energy, Office of FES, using the DIII-D National Fusion Facility under DE-FC02-04ER54698, DE-AC02-09CH11466, DE-AC52-07NA27344.

### I-3: Integrated data analysis for measurements in fusion devices - concept and applications

R. Fischer<sup>1</sup> and the ASDEX Upgrade Team<sup>1</sup>

<sup>1</sup>*Max-Planck-Institut für Plasmaphysik, Boltzmannstr 2, 85748 Garching, Germany*

E-mail of Corresponding Author: [rainer.fischer@ipp.mpg.de](mailto:rainer.fischer@ipp.mpg.de)

A major challenge in nuclear fusion research is the coherent combination of data from heterogeneous diagnostics and modelling codes [1]. Different techniques for measuring the same subset of physical parameters provide complementary and redundant data for, e.g., improving the reliability of physical parameters, increasing the spatial and temporal resolution of profiles, considering the diagnostics modelling dependencies and resolving data inconsistencies. Modelling codes provide additional physical information allowing for an improved treatment of ill-posed inversion problems such as the equilibrium reconstruction.

Integrated Data Analysis (IDA) [2] at ASDEX Upgrade routinely combines measurements of lithium beam emission (LIB), interferometry, electron cyclotron emission (ECE), and Thomson scattering, for a joint estimation of electron density and temperature profiles. Due to the entanglement of the plasma profiles with the magnetic equilibrium they both benefit from their combined analysis. Additionally, the combination with poloidal flux diffusion modelling provides valuable equilibrium constraints via the flux surface averaged toroidal current density. The combination of all available measured and modelled data allows to overcome, e.g., the persisting problem of missing regular and reliable magnetic measurements in the plasma core for the reconstruction of full current and  $q$ -profiles.

The concept of IDA in the framework of Bayesian probability theory will be introduced and contrasted with conventional data analysis. Applications at various fusion devices will be summarised. Routine applications and the recent progress at ASDEX Upgrade in profile and equilibrium reconstruction based on a comprehensive set of measurements and modelling will be shown.

#### References:

- [1] FISCHER, R., DINKLAGE, A., PASCH, E., "Bayesian modelling of fusion diagnostics", Plasma Phys. Control. Fusion 45 1095-1111 (2003)
- [2] FISCHER, R., et al., "Integrated data analysis of profile diagnostics at ASDEX Upgrade", Fusion Sci. Technol. 58 675-684 (2010)

## List of Regular Orals:

**O-1:** Hasegawa M., *Modifications of Plasma Control System and Central Control System for Integrated Control of Long Plasma Sustainment on QUEST*

**O-2:** Asenjo J., *Control and Data Acquisition System for SCR-1 Stellarator*

**O-3:** Xiao B.J., *Integrated Plasma Control for Long Pulse Advanced Plasma Discharges on EAST Kicks on TCV*

**O-4:** Lee W., *New Control Systems at KSTAR Compatible with ITER Standard Technologies*

**O-5:** Ravenel N. on behalf of Colnel J., *Adapting DCS Real Time Framework for WEST Plasma Control*

**O-6:** Santraine B., *Status of the CODAC System for WEST*

**O-7:** Tak T., *Conceptual Design of New Data Integration and Process System for KSTAR Pulse and Data Scheduling*

**O-8:** Spring A., *Plugging Physics into the W7-X CoDaC Framework*

**O-9:** Nakanishi H., *Integrated Radiation Monitoring and Interlock System for the LHD Deuterium Experiments*

**O-10:** Luchetta A., *Instrumentation and Control for the Neutral Beam Test Facility*

**O-11:** Winter A., *The ITER Real-Time Framework Final Design*

**O-12:** Pedica R. on behalf of Fernández-Hernando J.L., *The ITER Interlock System*

**O-13:** Davis W., *Integration of Electrical Networks I&C to ITER CODAC*

**O-14:** Prokopas M., *ITER Control System Model: A Full-Scale Simulation Platform for the CODAC Infrastructure*

**O-15:** Cruz N., *On the Control System Preparation for Experiments on ELM Pacing with Vertical kicks on TCV*

**O-16:** Walker M.L., *Enabling Co-Simulation of a Tokamak Plant Model and Plasma Control System*

**O-17:** Snipes J.A., *The Preliminary Design of the ITER Plasma Control System*

**O-18:** Treutterer W., *The Preliminary Architectural Design of the ITER Plasma Control System*

**O-19:** Raupp G., *Exception Handling in the Preliminary Design of the ITER Plasma Control*

**O-20:** De Vries P.C., *Preparing the PCS Final Design for ITER First Plasma*



- O-21:** Miyata Y., *Investigation of Methods for Mitigating Influences of Magnetic Measurement Noises on Equilibrium Control in JT-60SA*
- O-22:** Hu F., *Implementation of the On-line Density Limit Disruptions Prediction and Avoidance System Based on Neural Networks*
- O-23:** Joung S., *Neural Network Based Real-Time Reconstruction of KSTAR Magnetic Equilibrium and Imputation with Bayesian Scheme*
- O-24:** Clement M., *GPU Based Optimal Control Techniques for Resistive Wall Mode (RWM) Feedback in Tokamaks*
- O-25:** Dreval M.B., *Microprocessor-Based Digitizers Combined with Preamplifiers and Detectors as a Solution for EMI Suppression in U-3M*
- O-26:** Semenov I., *Online Processing of Large Volume Experimental Data in Strong Electromagnetic and Radiation Fields in ITER Neutron Diagnostics*
- O-27:** Taliencio C., *A Framework for the Integration of Linux FPGA SoC Devices*
- O-28:** Holtz A., *Continuous Acquisition and Storage of Wendelstein 7-X Data*
- O-29:** Dumke S., *Next Generation Web Based Live Data Monitoring for W7-X*
- O-30:** Wang F., *Study of Data Statistics and Retrieval for EAST MDSplus Data System*
- O-31:** Castro R., *ITER Unified Data Access (UDA)*
- O-32:** Piglowski D.A., *Evaluation of the ITER Data Archiving Network API on the DIII-D Tokamak*
- O-33:** Fredian T., *MDSplus Yesterday, Today and Tomorrow*
- O-34:** Fridrich D., *Hierarchical Dynamic Containers for Fusion Data*
- O-35:** Zheng W., *Distributed Database Based Data Storage and Manage System for Future Fusion Experiment*
- O-36:** Sammulu B.S., *TokSearch: A Search Engine for Fusion Experimental Data*
- O-37:** Stillerman J., *Navigational Data Management*
- O-38:** Iannone F., *MARCONI FUSION: The New High Performance Computing Facility for European Nuclear Fusion Modeling*
- O-39:** Esquembri S., *Methodology for the Implementation of Real Time Image Processing Systems Using FPGAs and GPUs and Their Integration in EPICS Using Nominal Device Support*
- O-40:** Farthing J., *Status of ITER Remote Experimentation Centre*

**O-41:** Rigoni A., *Assessing Remote Data Access feasibility for the ITER Remote Experimentation Centre*

**O-42:** Yamanaka K., *On-demand File Transfer for ITER Remote Experiments*

**O-43:** Schissel D.P., *Remote Operation of EAST*

**O-44:** Erickson K.G., *NSTX-U Advances in Real-Time Deterministic PCIe-Based Internode Communication*

**O-45:** Emoto M., *Inter-Application Communication during LHD Consecutive Short Pulse Discharge Experiment*

**O-46:** Kwon G., *Development Real-Time Data Archive System for KSTAR Real-Time Network*

## O-1: Modifications of plasma control system and central control system for integrated control of long plasma sustainment on QUEST

Makoto Hasegawa<sup>1</sup>, Kazuo Nakamura<sup>1</sup>, Kazuaki Hanada<sup>1</sup>, Shoji Kawasaki<sup>1</sup>, Hiroshi Idei<sup>1</sup>, Kazutoshi Tokunaga<sup>1</sup>, Yoshihiko Nagashima<sup>1</sup>, Takumi Onchi<sup>1</sup>, Kengoh Kuroda<sup>1</sup>, Osamu Watanabe<sup>1</sup>, Aki Higashijima<sup>1</sup>, and Takahiro Nagata<sup>1</sup>

<sup>1</sup> *Research Institute for Applied Mechanics, Kyushu University, Kasuga, Fukuoka, Japan*

E-mail of Corresponding Authors: [hasegawa@triam.kyushu-u.ac.jp](mailto:hasegawa@triam.kyushu-u.ac.jp), [nakamura@triam.kyushu-u.ac.jp](mailto:nakamura@triam.kyushu-u.ac.jp), [hanada@triam.kyushu-u.ac.jp](mailto:hanada@triam.kyushu-u.ac.jp), [kawasaki@triam.kyushu-u.ac.jp](mailto:kawasaki@triam.kyushu-u.ac.jp), [idei@triam.kyushu-u.ac.jp](mailto:idei@triam.kyushu-u.ac.jp), [tokunaga@triam.kyushu-u.ac.jp](mailto:tokunaga@triam.kyushu-u.ac.jp), [nagashima@triam.kyushu-u.ac.jp](mailto:nagashima@triam.kyushu-u.ac.jp), [onchi@triam.kyushu-u.ac.jp](mailto:onchi@triam.kyushu-u.ac.jp), [kuroda@triam.kyushu-u.ac.jp](mailto:kuroda@triam.kyushu-u.ac.jp), [rwata@triam.kyushu-u.ac.jp](mailto:rwata@triam.kyushu-u.ac.jp), [higashi@triam.kyushu-u.ac.jp](mailto:higashi@triam.kyushu-u.ac.jp), [nagata@triam.kyushu-u.ac.jp](mailto:nagata@triam.kyushu-u.ac.jp)

Achievement of steady state operation (SSO) is one of important issues for future magnetic fusion devices. The world record of plasma duration on tokamaks for more than 5h16min was achieved in TRIAM-1M [1], where particle balance and power balance are investigated. On QUEST, which is a middle sized spherical tokamak installed on the same place after the closing of TRIAM-1M experiments, these issues are also vigorously investigated, and the fully non-inductive plasma start-up and its maintenance up to 1h55min was successfully achieved [2] with a microwave of 8.2 GHz, 40 kW and well-controlled gas fueling and plasma facing wall (PFW) temperature of 373 K.

On QUEST, the hot wall which can be actively heated by electrical heaters was installed inside vacuum vessel in 2014, and the plasma discharge is sustained with high temperature PFW to investigate particle balance such as wall pumping properties. The function of active cooling for hot wall with the cooling water will be installed in 2017 spring. These controls of heating with electrical heaters and cooling with cooling water will be managed by the central control system and its peripheral subsystems with the coordination of them. On the other hand, the gas fueling during plasma discharge is feed-back controlled with referring to the signal level of H $\alpha$  which is an indicator of in-coming H flux to PFWs. This control is managed by a Proportional-Integral-Differential (PID) control on the plasma control system using a mass-flow controller. The modifications and coordination of these control systems for long discharges are introduced.

### References:

- [1] ZUSHI, H., et al, "Steady-state tokamak operation, ITB transition and sustainment and ECCD experiments in TRIAM-1M", Nuclear Fusion, **45** (2005) S142-S156.
- [2] HANADA, K., et al, Investigation of hydrogen recycling property and its control with hot wall in long duration discharges on QUEST, Nuclear Fusion, (2017) to be published.

## O-2: Control and data acquisition system for SCR-1 Stellarator

J. Asenjo<sup>1</sup>, V.I. Vargas<sup>1</sup> and J. Mora<sup>1</sup>

<sup>1</sup>*Instituto Tecnológico de Costa Rica, Cartago, 30101, Costa Rica*

E-mail of Corresponding Author: [jasca.tec@gmail.com](mailto:jasca.tec@gmail.com)

The SCR-1 is a small modular Stellarator designed, constructed, and implemented at the Instituto Tecnológico de Costa Rica [1]. This fusion research device is dependent on several subsystems, responsible for the different stages involved in the operation of the machine. The design and implementation of the SCR-1's control system is introduced and discussed in this article. The described development includes the validation and integration of vacuum pumping, gas injection, ECR heating, diagnostics, and magnetic confinement systems of the SCR-1.

The control system was implemented on a National Instruments® PXIe® platform. By data flow programming, it was possible to develop different algorithms for the simultaneous execution of four threads during the plasma discharge sequence (device safety, gas injection, data acquisition and plasma discharge), where the primary goal is to implement a robust and secure system considering the integrity and safety of the SCR-1 work team and the hardware involved [2]. Through the implementation of this control and data acquisition system, it was possible to perform the first plasma discharge and, therefore, obtain the first results of the device [3].

### References:

- [1] VARGAS, V.I., et al., Implementation of Stellarator of Costa Rica 1 SCR-1, 26th IEEE Symposium on Fusion Engineering (SOFE), May 31-June 4 2015, Austin, Texas. USA
- [2] ASENJO, J., Automatización del proceso de generación de plasma en el Stellarator de Costa Rica 1, Graduation Project Report, School of Electronic Engineering (ITCR), June 2016, Cartago, Costa Rica
- [3] MORA, J., et al., First Results of the Stellarator of Costa Rica 1 (SCR-1), 26th IAEA Fusion Energy Conference (FEC IAEA), 17–22 October 2016, Kyoto, Japan

### **O-3: Integrated plasma control for long pulse advanced plasma discharges on EAST kicks on TCV**

B.J. Xiao<sup>1,2</sup>, Z.P. Luo<sup>1</sup>, Q.P. Yuan<sup>1</sup>, K. Wu<sup>1</sup>, Y. Guo<sup>1</sup>, Y.H. Wang<sup>1</sup>, G. Calabrò<sup>3</sup>, F. Crisanti<sup>3</sup>, R. Albanese<sup>4</sup>, R. Ambrosino<sup>4</sup>, G. De Tommasi<sup>4</sup>, F. Crisanti<sup>3</sup>, Y. Huang<sup>1</sup>, D.A. Humphreys<sup>5</sup>

<sup>1</sup>*Institute of Plasma Physics, Chinese Academy of Sciences, Hefei, 230031, China*

<sup>2</sup>*School of Nuclear Science and Technology, University of Science and Technology of China, Hefei 230031, China*

<sup>3</sup>*ENEA Unità Tecnica Fusione, C.R. Frascati, Via E. Fermi 45, 00044 Frascati, Roma, Italy*

<sup>4</sup>*CREATE, Università di Napoli Federico II, Università di Cassino and Università di Napoli Parthenope, Via Claudio 19, 80125, Napoli, Italy*

<sup>5</sup>*General Atomics, DIII-D National Fusion Facility, San Diego, CA, USA*

E-mail of Corresponding Author: [bjxiao@ipp.ac.cn](mailto:bjxiao@ipp.ac.cn)

For long pulse or even steady-state advanced plasma discharges, it is necessary to keep many plasma parameters such as plasma shape, loop voltage, plasma pressure and divertor heat load in a steady state way. For the divertor target heat load control, radiation in the scrape-off layer or in front of divertor targets is one of the effective methods. We used mid-plane impurity seeding by Super-Sonic Molecular Beam Injection (SMBI) to feedback the total radiation. To increase the feedback robustness and increase the radiation in divertor region, we used additional impurity gas puff in front of the divertor target. Either in L-mode and H-mode discharges, radiation can be effectively controlled and the divertor heat load decreased significantly. Another way for the heat load spread is to use advanced magnetic configuration such as snowflake or quasi-snowflake to enhance scrape-off layer transport and to increase plasma wetted area on divertor target due to larger magnetic flux expansion. Pioneer EAST experiment has shown significant peak heat load reduction in L-mode operation [1]. In last campaign, we extended the quasi-snowflake (QSF) discharge to H-mode and long pulse operation together with the radiation feedback control. Long pulse operation needs efficient non-inductive current drive, we used Lower Hybrid Wave (LHW). It was found there is a good coupling between the plasma and LHW under QSF shape. To avoid the plasma current overdriven, we implemented loop voltage control. Plasma current was controlled by the PF coil set and the loop voltage was controlled by LHW. In addition, we also demonstrated the control of the plasma pressure by using LHW. Under QSF shape in upper single null, we achieved 20 second H-mode non-inductive operation with  $\beta_{\text{tap}} \sim 2$  and plasma current  $\sim 250$  kA. The most recent results and the plasma control activities will be reported in this paper.

#### **References:**

[1] CALABRO, G, et al, Nucl. Fusion 55 (2015) 083005.

#### **O-4: New control systems at KSTAR compatible with ITER standard technologies**

Woongryol Lee<sup>1</sup>, Taegu Lee<sup>1</sup>, Giil Kwon<sup>1</sup>, Jinseop Park<sup>1</sup>, Taehyun Tak<sup>1</sup>, Myungkyu Kim<sup>1</sup>,  
Yeon-jung Kim<sup>1</sup>, and Jaesic Hong<sup>1</sup>

<sup>1</sup>*Control Team, National Fusion Research Institute, Daejeon, South Korea*

E-mail of Corresponding Author: [wrlee@nfri.re.kr](mailto:wrlee@nfri.re.kr)

The KSTAR control team has responsible to develop not only for ordinary machine control systems but also the data acquisition system for diagnostics and real time control. Our development efforts are naturally concentrated on the system automation and standardization. More than 20 control systems have been implemented based on standard custom libraries [1]. For the hardware standardization, we developed a new digital device based on the MTCA.4 Standard [2]. In addition, we have been performed intensive collaboration with ITER due to KSTAR has very ITER relevant control system environment [3]. A new demonstration task was also successfully executed to evaluate the latest CODAC standards during the past two years. As a result, fully ITER relevant control system was installed and operates as a key part of KSTAR control system itself.

The collaboration also gives us an inspiration to make the next generation of Tokamak control system at KSTAR. By the benefit of CODAC core technologies, we can smoothly move our main control scheme to the next generation phase.

Several functions are prioritized to make seamless control system upgrade. To increase system reliability and maintainability and to reduce performance limitations, we decide to adopt the ITER SDN as an auxiliary interface for the real time feedback control [4]. ITER TCN also good candidate for the global time based system operation. Recently, we have investigating the next generation real time software architecture for the plasma control. We are finished prototyping of Function Block based software architecture help with IO export. Collected new functionality from CODAC Core System was realized as standard libraries and deployed. In this paper, we introduce new function based real time feedback control system on plasma density, and test results.

#### **References:**

- [1] LEE, W., et al., Fusion Engineering and Design. 89, 608-613 (2014)
- [2] LEE, W., et al., 20th IEEE-NPSS Real Time Conference , (2016)
- [3] <https://www.iter.org/newsline/248/1412>
- [4] KWON, G., et al., 29th Symposium on Fusion Technology, (2016)

## O-5: Adapting DCS real time framework for WEST plasma control

J. Colnel<sup>1</sup>, N. Ravenel<sup>1</sup>, R. Nouailletas<sup>1</sup>, G. Caulier<sup>1</sup>, P. Moreau<sup>1</sup>, W. Treutterer<sup>2</sup>, K. Lueddecke<sup>3</sup>, R. Cole<sup>3</sup>

<sup>1</sup> CEA-IRFM, F-13108 Saint-Paul-Les-Durance, France

<sup>2</sup> IPP Garching, Germany

<sup>3</sup> Unlimited Computer Systems GmbH, Germany

E-mail of Corresponding Author: [julian.colnel@cea.fr](mailto:julian.colnel@cea.fr)

In December 2016, the experimental Tokamak WEST has produced its first plasma. A goal of WEST is to test ITER-like plasma facing components to minimize the risk of ITER divertor procurement and operation. The plasma control system (PCS) will play a crucial role to achieve WEST objectives. It features advanced functions such as the handling of events or exceptions and a segmented approach of the plasma discharge. The WEST PCS builds on DCS (Discharge Control System), the existing RT framework developed at IPP Garching, adapted to WEST requirements. The main challenges of the adaptation of DCS to WEST are: DCS was designed to be the master of the acquisition network whereas the WEST framework infrastructure requires considering it as a standard real time network unit. DCS use an absolute time in contrary of WEST where time is relative to the pulse.

Last years were devoted to integrate DCS with the WEST real time environment. DCS was first interfaced to the existing pulse sequence manager inference engine through a Middleware Oriented Messaging system. The DCS Cycle Master has been fitted to the WEST Timing System using dedicated polling application. An application has been developed to allow DCS to send and receive time events in the WEST timing network. Finally, after having developed a specific gateway and driver, DCS has been interfaced to the new real-time reflective memory network that allows sharing data between the different control and acquisition units.

This paper reports on the status of the WEST PCS development. It will start by describing constraints and challenges. The chosen technical solution will be described as well as the development and integration work. Finally, it will discuss the results obtained during the first WEST experimental campaign and the future plans.

## O-6: Status of the CODAC system for WEST

B. Santraine<sup>1</sup>, N. Ravenel<sup>1</sup>, J. Colnel<sup>1</sup>, G. Caulier<sup>1</sup>, P. Moreau<sup>1</sup>, F. Leroux<sup>1</sup>, A. Berne<sup>2</sup>, C. Chavda<sup>3</sup>

<sup>1</sup>*CEA-IRFM, F-13108 Saint-Paul-Les-Durance, France*

<sup>2</sup>*Avisto, F-06220 Vallauris, France*

<sup>3</sup>*IPR, Gandhinagar District, Bhat, Gujarat, India*

E-mail of Corresponding Author: [benjamin.santraine@cea.fr](mailto:benjamin.santraine@cea.fr)

The WEST (W – for Tungsten – Environment in Steady state Tokamak) project is aiming at minimizing technology and operational risks of a full tungsten actively cooled divertor on ITER. It was launched in 2013 and consists in transforming the Tore Supra tokamak into an X point divertor device, while taking advantage of its long discharge capability. In December 2016, the WEST tokamak produced its first plasma and the preparation for the first experimental campaign in spring 2017 is on-going.

In addition to the mechanical in-vessel components modification, several elements of the Control Data Access and Communication (CODAC) system have been modified, updated or even completely redesigned. A new architecture for the acquisition units has been developed and several critical systems have been produced accordingly. Some backbone systems, which impact the behaviour of the entire CODAC system, have also been updated and required major changes and qualification.

This paper reports on the status of the WEST CODAC system. It will start by describing the reasons which lead to the system update. The choice for the technical solution (computer with PXI acquisition boards) will be explained as well as the development and integration work. Finally, it will present the last results obtained during the experiments and the objectives for the upcoming experimental campaigns.



## **O-7: Conceptual design of new data integration and process system for KSTAR pulse and data scheduling**

Taehyun Tak<sup>1</sup>, Jaesic Hong, Kap-rae Park, Woongryul Lee, Taegu Lee, Giil Kwon, and Jinseop Park

*National Fusion Research Institute (NFRI), Daejeon, Republic of Korea*

E-mail of Corresponding Author: [thtak@nfri.re.kr](mailto:thtak@nfri.re.kr)

The KSTAR control and data acquisition systems mainly use data storing layer of MDSPlus for diagnostic data and channel archiver for EPICS based control system data. Besides these storing system, KSTAR has various types of data such as user logs from RDB (Relational Database) and various types of logs from the control system.

Huge scientific machine like KSTAR need to implement various type of use case for scheduling data for operation. New data integration and process system is aimed to design for plasma pulse and data scheduling with PASS [1] according to KSTAR event. KSTAR Data Scheduling System (KDSS) designed under the big data software infrastructure and frameworks. KDSS is for handling events synchronized with the KSTAR EPICS event and other data sources such as rest API and logs, for integrating and processing data from different data sources, and visualizing data.

In this paper, we explain detailed design concept of KDSS and demo scheduling use case with this system.

### **References:**

[1] LEE, W., et al. "Conceptual design and implementation of Pulse Automation and Scheduling System for KSTAR." Fusion Engineering and Design 96 (2015): 830-834.

## O-8: Plugging physics into the W7-X CoDaC framework

Anett Spring, Torsten Bluhm, Michael Grahl, Martin Grün, Andreas Holtz, Jon Krom, Georg Kühner, Heike Laqua, Marc Lewerentz, Heike Riemann, Andreas Werner and the W7-X team

*Max Planck Institute for Plasma Physics, Greifswald, Germany*

E-mail of Corresponding Author: [anett.spring@ipp.mpg.de](mailto:anett.spring@ipp.mpg.de)

The first operation campaign of Wendelstein 7-X proved its control and data acquisition system to be capable of continuous operation. Conditioning programs up to 10 minutes duration – comprising up to 20 consecutive plasma discharges - have been controlled successfully by the W7-X Segment Control system. On the way to more sophisticated physics experiment programs the CoDaC framework offers several plug-in points for physics model based program evaluation, scheduling, and data processing. This contribution will highlight some examples:

- A reasonable experiment program planning is assisted by experiment parameter abstraction providing physics oriented views and an extendible, model-based pre-checking of planned programs. The underlying component model framework generates views from any technical or physical parameter constraints as long as they can be described in straight dependencies or even complex mappings.
- The experiment session workflow is supported by an automatic extraction of typical program parameters and categorizing tags – throughout the integrated W7-X segment control tools: from planning, execution and monitoring to logbook recording. Besides available standard functions, more physics oriented evaluation functions can be added.
- The integrated exception and event handling of the W7-X segment control system supports a physics driven experiment scheduling. The detection of pre-defined (plasma) events can induce predefined reactions on the program's progress by switching segments on event occurrence or even jumping forward within the planned program's schedule.
- For fast evaluation of experiments the online data analysis framework allows the processing of live data in parallel to the experiment's run for online monitoring and archiving. The used analysis functions have to be optimized for performance and can be verified offline on basis of archived data using the same software framework.

## O-9: Integrated radiation monitoring and interlock system for the LHD deuterium experiments

H. Nakanishi<sup>1,2</sup>, M. Yokota<sup>1</sup>, M. Aoyagi<sup>1</sup>, M. Ohsuna<sup>1</sup>, T. Ito<sup>1</sup>, S. Imazu<sup>1</sup>, M. Nonomura<sup>1</sup>, K. Ogawa<sup>1,2</sup>, M. Isobe<sup>1,2</sup>, N. Akada<sup>1,2</sup>, M. Tanaka<sup>1,2</sup>, H. Hayashi<sup>1</sup>, H. Miyake<sup>1</sup>, H. Ogawa<sup>1</sup>, H. Maeno<sup>1</sup>, M. Emoto<sup>1</sup>, M. Yoshida<sup>1</sup>, T. Yoshida<sup>1</sup>, S. Sakakibara<sup>1,2</sup>, S. Ishiguro<sup>1,2</sup>, and M. Osakabe<sup>1,2</sup>

<sup>1</sup> National Institute for Fusion Science, NINS, 322-6 Oroshi-cho, Toki 509-5292, Japan

<sup>2</sup> SOKENDAI (The Graduate University for Advanced Studies), 322-6 Oroshi-cho, Toki 509-5292, Japan

E-mail of Corresponding Author: [nakanisi@nifs.ac.jp](mailto:nakanisi@nifs.ac.jp)

The Large Helical Device (LHD) plans to start the deuterium experiment in March 2017, in which further plasma performance improvement is envisaged to provide a firm basis for the helical reactor design. Some major upgrades of facilities have been made for safe and productive deuterium experiments. For the radiation safety, tritium removal system, integrated radiation monitoring system and access control system have been newly installed. Each system has new interlock signals not to lead to any unsafe plasma operations or plant conditions. Major interlock extensions have been implemented as a part of the integrated radiation monitoring system, which also has interconnection to the central operation and control system.

The radiation monitoring system named RMSAFE (Radiation Monitoring System applicable to Fusion Experiments) has already been operating for monitoring  $\gamma(X)$ -rays in LHD [1,2]. Some neutron measurements have been additionally applied for the deuterium experiments. The LHD data acquisition system named LABCOM can acquire and process 24x7 continuous data streams [3]. Since  $\gamma(X)$ -ray and neutron measurements require higher availability, the sensors, controllers, data acquisition computers, network connections, and the visualization servers have been designed to be duplicated or multiplexed for redundancy. The radiation monitoring displays in the LHD control room have been carefully designed to have good conspicuousness, and to make immediately aware of several alerts against the dose limits. The radiation safety web pages have been also upgraded to show both dose rates of  $\gamma(X)$ -rays and neutrons always to the public.

### References:

- [1] MIYAKE, H., et al., 10th Int'l Radiation Protection Association (IRPA-10), 14–19 May 2000, Hiroshima, Japan, P-6a-313 (2000).
- [2] UDA, T., et al., J. Fusion Energy 16, 1/2, pp.167–173 (1997).
- [3] NAKANISHI, H., et al., Fusion Eng. Des. 112, pp.778–782 (2016).

## O-10: Instrumentation and Control for the Neutral Beam Test Facility

A. Luchetta<sup>1</sup>, G. Manduchi<sup>1</sup>, C. Taliercio<sup>1</sup>, A. Rigoni<sup>1</sup>, N. Pomaro<sup>1</sup>, S. Dal Bello<sup>1</sup>, M. Battistella<sup>1</sup>, L. Grandò<sup>1</sup>, F. Paolucci<sup>2</sup>, C. Labate<sup>2</sup>

<sup>1</sup> *Consorzio RFX, corso Stati Uniti, 4, 35127 Padova, Italy*

<sup>2</sup> *Fusion for Energy, c/ Josep Pla, nº 2, Torres Diagonal Litoral, Edificio B3, 08019 Barcelona, Spain*

E-mail of Corresponding Authors: [adriano.luchetta@igi.cnr.it](mailto:adriano.luchetta@igi.cnr.it)

The Neutral Beam Test Facility [1] is under construction in Padova, Italy with the aim of developing and testing the technologies needed to meet the advanced requirements of the ITER heating neutral beam injectors (HNBs). It includes two experiments, namely SPIDER, the full-size ITER HNB ion source experiment, and MITICA the prototype of the ITER HNB.

The construction of SPIDER is near to completion. SPIDER instrumentation and control (I&C) is classically organized in three tiers - conventional control, investment protection (interlock), and personnel safety - and three layers – central, plant system, and plant unit.

Conventional control and the interlock systems have been already developed and tested and are ready to undergo the integrated commissioning along with important operation plant units such as the power supply, gas and vacuum, and cooling systems.

Conventional control integrates a set of standard software frameworks [2]. It supports all functions that are typical of long-lasting fusion experiments, such as real-time control, event-driven data acquisition, and data streaming. The interlock system provides fast (< 10  $\mu$ s reaction time) and slow (< 20 ms reaction time) protection functions. The safety system is under development and will include a set of safety-related functions associated with specific Safety Integrity Levels according to IEC 61508.

The paper will present the architecture of the three-tier I&C system with reference to system requirements, technical solution proposed and issues found in the system development. In detail, the implementation of the interlock and safety tiers will be discussed with reference to the requirements set by ITER in the plant control design handbook.

Finally, the SPIDER I&C example will be discussed with the perspective of the evolution towards the MITICA I&C for which the ITER constraints are stringent.

### References:

[1] TOIGO, V., et al., Fus. Eng. Des., to appear.

[2] MANDUCHI, G., et al., this IAEA Technical Meeting.

## O-11: The ITER real-time framework final design

A. Winter<sup>1</sup>, B. Bauvir<sup>1</sup>, R. Lange<sup>1</sup>, K. Erickson<sup>2</sup>, A. Stephen<sup>3</sup>, and W. Treutterer<sup>4</sup>

<sup>1</sup>*ITER Organization, Route de Vinon-sur-Verdon - 13067 St Paul Lez Durance - France*

<sup>2</sup>*Princeton Plasma Physics Laboratory, Princeton, NJ, USA*

<sup>3</sup>*Culham Centre for Fusion Energy, Abingdon, UK*

<sup>4</sup>*Max-Planck-Institut für Plasmaphysik, Garching, Germany*

E-mail of Corresponding Author: [axel.winter@iter.org](mailto:axel.winter@iter.org)

This paper will provide an overview of the various real-time software processes which are distributed across ITER, the infrastructure and strategy being put in place by the CODAC section to implement this functionality. It comprises real-time processing done at a diagnostic level to process the initially acquired data and produce a meaningful signal for plasma control, which is typically a physics measurement (e.g. the plasma current). These signals are used among many others in central plasma control where they will be processed and control algorithms will be applied. The final aspect is the processing in the actuator systems to produce the desired control behaviour. Generally speaking, the responsibility for I&C functions is within the procurement packages and ITER CODAC supports the activities by setting standards, providing tools and advice. In case of diagnostics, CODAC and the ITER diagnostic division collaborate closely to provide a common solution for real-time processing (both CPU and FPGA/GPU-based). This solution will be used by the diagnostic plant systems in order to implement real-time functions in their scope as well as by CODAC to implement the central control tasks (e.g. the Plasma Control System). Developments at existing machines have shown that certain advanced machine protection functions have reached complexity levels which are difficult to satisfy using typical interlock systems (e.g. the protection of a beryllium first wall). One option to address these complex functions is increasing the quality of the real-time software to a level which is deemed acceptable to meet the reliability requirements set by the machine protection functions. The ITER real-time framework was designed with that potential use case in mind.

Design work has been ongoing throughout the year 2016 to provide the appropriate software infrastructure which fulfils the requirements. A final design review was completed successfully in late 2016 and implementation started in early 2017. This paper will present an overview of the collected functional and performance requirements for the ITER real-time infrastructure. The full overview of the design will be given with special emphasis on the new features foreseen to address specific use cases identified during the requirements capture. The design has been developed in a broad international collaboration with experts from PPPL, CCFE and IPP Garching. In addition to the implementation strategy, this paper will also outline the plan to involve the fusion community in the early deployment and testing of the ITER real-time framework.

## O-12: The ITER interlock system

J.L. Fernández-Hernando<sup>1</sup>, D. Carrillo<sup>2</sup>, G. Ciusa<sup>3</sup>, Y. Liu<sup>1</sup>, I. Prieto-Díaz<sup>4</sup>, R. Pedica<sup>3</sup>,  
S. Sayas<sup>5</sup>, A. Vergara<sup>6</sup>

<sup>1</sup> ITER Organization, route de Vinon sur Verdon, CS90 046, 13067 St. Paul lez Durance Cedex, France

<sup>2</sup> Ciemat, Av. Complutense, 40, 28040 Madrid, Spain

<sup>3</sup> Vitrociset, via Tiburtina 1020, 00156 Roma, Italy

<sup>4</sup> Iberdrola Ingeniería y Construcción, Av. Manoteras 20, 28050 Madrid, Spain

<sup>5</sup> Arkadia, 298 avenue du club Hippique, 13090 Aix-en-Provence, France

<sup>6</sup> European Spallation Source ERIC, P.O Box 176, SE-221 00 Lund, Sweden

E-mail of Corresponding Author: [juanluis.fernandez-hernando@iter.org](mailto:juanluis.fernandez-hernando@iter.org)

ITER involves the integration of numerous sophisticated systems, many of which must operate reliably close to their performance limits in order to achieve the project's scientific goals. The teams responsible for exploiting the tokamak will require sufficient operational flexibility to explore a wide range of plasma scenarios within an operational framework that ensures that the integrity of the machine and safety of the environment and personnel are not compromised. The instrumentation and control (I&C) systems of ITER are divided into three separate tiers: the conventional I&C, the safety system and the interlock system. This paper focuses on the last of these. The operational experience from existing tokamaks and large superconducting machines, together with many specific aspects of the ITER facility, has been taken into account in the design of the ITER interlock system. This consists of a central element, the Central Interlock System, and several local elements, distributed across the various plant systems of the tokamak and referred to as Plant Interlock Systems. Each Plant Interlock System is connected to dedicated networks and communicates its status and interlock events to the Central Interlock System, which in turn sends the required interlock actions to the Plant Interlock Systems. The Central Interlock System is also responsible for communicating the status of each system to the operators in the main control room. These operators will use the Central Interlock System to perform functionalities such as overrides, resets of central interlock functions and configuration of Plant Interlock Systems. Three different types of architecture have been developed: a slow one, based on PLCs, for functions for which response times longer than 300 ms are adequate, a fast one, based on FPGAs, for functions which require response times beyond the capabilities of the PLC, and a hardwired one to synchronise all the systems involved in a fast discharge of the superconducting coils. The overall design of the Central Interlock System was presented and approved for manufacturing in a Final Design Review in 2016.

### References

- [1] SCIBILE, L., *et al.*, "AN OVERVIEW OF THE ITER INTERLOCK AND SAFETY SYSTEMS" Proceedings of ICALEPCS2009, WEC005, Kobe, Japan
- [2] BARRERA, E., *et al.*, "Implementation of ITER fast plant interlock system using FPGAs with cRIO". Proceedings of the 2016 IEEE-NPSS Real Time Conference (RT) (20161997)
- [3] WAGNER, S., *et al.*, "ARCHITECTURE FOR INTERLOCK SYSTEMS: RELIABILITY ANALYSIS WITH REGARD TO SAFETY AND AVAILABILITY" Proceedings of ICALEPCS2011, WEPMU006, Grenoble, France

## O-13: Integration of Electrical Networks I&C to ITER CODAC

William Davis<sup>1</sup>, Yinbo Ding<sup>1</sup>, Marco Ermirio<sup>1</sup>, Joel Hourtoule<sup>1</sup>, Ralph Lange<sup>1</sup>, Cyril Lescure<sup>2</sup>,  
Ruben Marti<sup>3</sup>, Vishnukumar Patel<sup>1</sup>, Shrikrushna Patil<sup>4</sup>, Jeremy Sanna<sup>1</sup>

<sup>1</sup>*ITER Organization, Route de Vinon-sur-Verdon, CS 90 046, 13067 St. Paul Lez Durance*

<sup>2</sup>*Fusion For Energy, Josep Pla, 2, Torres Diagonal Litoral B3, 08019 Barcelona*

<sup>3</sup>*GTD Sistemas De Información, Pg. Garcia Fària, 17 E-08005 Barcelona*

<sup>4</sup>*Tata Consultancy Services, Pune - 411057, Maharashtra, India*

E-mail of Corresponding Author: [william.davis@iter.org](mailto:william.davis@iter.org)

The ITER electrical networks are now being installed and commissioned on site and will be the first plant system operational at ITER. The steady state electrical network (SSEN) will supply continuous electrical power to steady state loads during all operating states of ITER. The pulsed power electrical network (PPEN) will meet the demanding power requirements from loads such as the coil power supplies (CPS) and heating and current drive systems (H&CD) which are only used during tokamak operations. There are approximately forty subsystems that make up all of SSEN and PPEN, which will be installed and commissioned in a staged approach to as required by the electrical consumers at ITER.

This staged process of installation and commissioning means that the system will be changing and expanding over the lifetime of the ITER project, presenting many challenges for integration. The main challenge is the repeated modification of an existing operational system without negatively affecting that operational system or the systems that it supports.

This paper describes the instrumentation and control (I&C) systems for SSEN and PPEN, in particular the strategy for staged integration of the I&C for each subsystem within the overall SSEN and PPEN I&C systems and ultimately with the ITER CODAC system. The overall system will use IEC 61850, Siemens S7 equipment and CODAC core system, with WinCC-OA and OPC-UA used for temporary interfaces. The control and network architecture, technologies, protocols and standards that are used will be described.



## O-14: ITER Control system model: a full-scale simulation platform for the CODAC infrastructure

M. Prokopas<sup>1,2</sup>, A. Wallander<sup>1</sup>, B. Bauvir<sup>1</sup>, J. Sousa<sup>2</sup>

<sup>1</sup>*ITER Organization, Route de Vinon-sur-Verdon, CS 90 046, St. Paul Lez Durance Cedex  
13067, France*

<sup>2</sup>*IST-IPFN, Av. Rovisco Pais 1, Lisbon 1049-001, Portugal*

E-mail of Corresponding Author: [Martynas.Prokopas@iter.org](mailto:Martynas.Prokopas@iter.org)

ITER Control System Model (ICM) is a currently developed simulation platform for CODAC [1], which is the conventional control system responsible for operating all plant systems of ITER. ICM is a full-scale implementation of CODAC that follows all ITER hardware and software conventions [2], but does not have any interfaces to other components of ITER nor any simulation of the physical processes. ICM currently consists of a single server cubicle that includes 2 virtualization devices (hypervisors) paired with a storage server, 8 high-performance computers (fast controllers) and 4 dedicated switches in order to simulate real-world performance of different CODAC networks. Hypervisors are capable of running hundreds of virtual servers, each fulfilling different plant system roles across the infrastructure of ITER. ICM is also designed to be fully expandable and additional components may be installed to provide better performance and to increase the number of servers for added functionality. In addition to running plant system simulations, ICM mirrors all CODAC support services as well (user access, software repository, IP management, etc.) and can thus run without any dependencies from external servers. Due to its isolated nature, ICM serves as an excellent test platform for CODAC technologies. It is used to verify the control system scalability and new software application releases before being rolled-out into operation. Combining all the different components, it is also capable of simulating CODAC at the production stage of ITER. In addition, ICM is currently under consideration to be used as an operator training platform and it may also be interfaced to other external simulators, including some form of process simulation, in order to provide a more powerful testing environment. This paper will give an overview of ICM, progress since its inception in 2014 and considered test cases for the near future, which will play an important role in the overall development of the ITER project.

### References:

- [1] N. UTZEL, et al., “ITER CODAC Status and Implementation Plan”, IEEE Trans. Nucl. Sci. 51, 700–707 (2010)
- [2] J.-Y. JOURNEAUX, “Plant Control Design Handbook” v7.0, ITER Org. (2017) [http://static.iter.org/codac/pcdh7/Folder%201/1-Plant\\_Control\\_Design\\_Handbook\\_27LH2V\\_v7\\_0.pdf](http://static.iter.org/codac/pcdh7/Folder%201/1-Plant_Control_Design_Handbook_27LH2V_v7_0.pdf)



## O-15: On the control system preparation for experiments on ELM pacing with vertical kicks on TCV

N. Cruz<sup>1</sup>, Y. Martin<sup>2</sup>, J-M. Moret<sup>2</sup>, S. Coda<sup>2</sup>, A.P. Rodrigues<sup>1</sup>, C.M.B.A. Correia<sup>3</sup>, B. Gonçalves<sup>1</sup>, the TCV team<sup>\*</sup>, and the EUROfusion MST1 Team<sup>†</sup>

<sup>1</sup>*Instituto de Plasmas e Fus~ao Nuclear, Instituto Superior Tecnico, Universidade de Lisboa, 1049-001 Lisboa, Portugal.*

<sup>2</sup>*Ecole Polytechnique Federale de Lausanne (EPFL), Swiss Plasma Center (SPC), CH-1015 Lausanne, Switzerland*

<sup>3</sup>*LIBPhys-UC, Department of Physics, University of Coimbra, P-3004 516 Coimbra, Portugal*

E-mail of Corresponding Author: [nunocruz@ipfn.tecnico.ulisboa.pt](mailto:nunocruz@ipfn.tecnico.ulisboa.pt)

High confinement plasma regimes (H-mode) are the scenarios with the highest fusion rates and the operating regime foreseen for the ITER scenario with  $Q_{DT} = 10$ . The steep gradients of density and temperature drive Magnetohydrodynamic (MHD) Edge Localized Modes (ELMs). Although ELMs are beneficial for controlling particle exhaust and plasma impurities, the excessive energy they deposit on the plasma facing components may lead to erosion or melting, reducing the components life cycle. By controlling the ELM frequency in an ELMy H-mode plasma it may be possible to reduce the energy expelled per ELM, mitigating damage to the tokamak parts.

One technique for mitigating these risks was first implemented successfully in TCV Ohmic H-mode plasmas, using the so called ELM pacing with vertical kicks [1]. TCV vertical stabilisation coils located inside the vessel proved to be well suited to apply the necessary perturbations to induce vertical displacements of the plasma. This method was then reproduced on AUG [2][3] and later on JET [4] with significant improvements.

During 2016 a set of experiments were planned to further study the physics of ELM pacing taking advantage of the new neutral beam heating (NBH) system installed on TCV [5]. This submission reports on the related preparation of the TCV digital vertical stabilization control system [6] actuating the in-vessel coils. A number of tools were deployed to drive a fast radial-field variation and preliminary experimental validation was carried out. The tools and simulations, as well as preliminary experiments aiming at evaluating the controller's accuracy are reported.

### References:

- [1] DEGELING, A., et al., Plasma Phys. Control. Fusion 45 (2003) 16371655.
- [2] MARTIN, Y., et al., EPS Conference (2004) P-4.133.
- [3] KIM, S.H., et al., Plasma Phys. Control. Fusion 51 (2009) 55021.
- [4] DE LA LUNA E., et al., Nucl. Fusion 56 (2016) 026001 (22pp).
- [5] KARPUSHOV, A.N., et al., Fusion Engineering and Design 9697 (2015) 493497.
- [6] CRUZ, N., et al., IEEE Transactions on Nuclear Science Vol. 62 No. 6 (2015) 3126-3133.

*This work has been carried out within the framework of the EUROfusion Consortium and has received funding from the Euratom research and training programme 2014-2018 under grant*

---

<sup>\*</sup> see appendix of S. Coda et al (OV/P-1) Proc. 26th IAEA Fusion Energy Conf. 2016, Kyoto, Japan.

<sup>†</sup> see appendix of H. Meyer et al (OV/P-12) Proc. 26th IAEA Fusion Energy Conf. 2016, Kyoto, Japan.

*agreement No 633053. The views and opinions expressed herein do not necessarily reflect those of the European Commission.*

*IST activities also received financial support from "Fundação para a Ciência e Tecnologia" through project UID/FIS/50010/2013.*

*This work was supported in part by the Swiss National Science Foundation.*

## **O-16: Enabling co-simulation of a tokamak plant model and plasma control system**

M.L. Walker, R. Johnson, B. Sammuli

*General Atomics, 3550 General Atomics Ct, San Diego CA, USA*

E-mail of Corresponding Author: [walker@fusion.gat.com](mailto:walker@fusion.gat.com)

A system for connecting the Plasma Control System and a model of the tokamak Plant in closed loop co-simulation for plasma control development has been in routine use at DIII-D for more than 20 years and at other fusion labs that use variants of the DIII-D PCS for approximately the last decade. Here, co-simulation refers to the simultaneous execution of two independent codes with the exchange of data - Plant actuator commands and tokamak diagnostic data - between them during execution. Interest in this type of PCS-Plant simulation technology has also been growing recently at other fusion facilities. In fact, use of such closed loop control simulations is assumed to play an even larger role in the development of both the ITER Plasma Control System (PCS) and the experimental operation of the ITER device, where they will be used to support verification/validation of the PCS and also for ITER pulse schedule development and validation.

We describe the key use cases that motivate the co-simulation capability and the features that must be provided by the Plasma Control System to support it. These features could be provided by the PCS itself or by a model of the PCS in Simulink. If the PCS itself is chosen to provide them, there are requirements imposed on the PCS architecture. If a PCS simulation is chosen, there are requirements imposed on the initial implementation of this simulation as well as long-term consequences for its continued development and maintenance. We describe these issues for each use case and discuss the relative merits of the two choices. Several examples are given illustrating uses of the co-simulation method to address problems of plasma control during the operation of DIII-D and of other devices that use the DIII-D PCS.

*Work supported by General Atomics' Internal Research and Development Funding and by the U.S. DOE under DE-FC02-04ER54698.*

## O-17: The preliminary design of the ITER plasma control system

J. A. Snipes<sup>1</sup>, G. Ambrosino<sup>2</sup>, S. Bremond<sup>3</sup>, M. Cinque<sup>2</sup>, G. De Tommasi<sup>2</sup>, P. C. De Vries<sup>1</sup>, F. Felici<sup>4</sup>, R. Felton<sup>5</sup>, J. Ferron<sup>6</sup>, Y. Gribov<sup>1</sup>, M. Hosokawa<sup>1</sup>, D. Humphreys<sup>6</sup>, A. Kavin<sup>7</sup>, R. Khayrutdinov<sup>8</sup>, S. H. Kim<sup>1</sup>, S. Konovalov<sup>8</sup>, M. Lehnen<sup>1</sup>, V. Lukash<sup>8</sup>, M. Mattei<sup>2</sup>, A. Mineev<sup>7</sup>, G. Pautasso<sup>9</sup>, A. Pironti<sup>2</sup>, G. Raupp<sup>9</sup>, F. Rimini<sup>5</sup>, M. Schneider<sup>1</sup>, W. Treutterer<sup>9</sup>, M. Walker<sup>6</sup>, A. Winter<sup>1</sup>, And L. Zabeo<sup>1</sup>

<sup>1</sup>ITER Organization, Route de Vinon sur Verdon, CS 90046, 13067 St Paul-lez-Durance, France

<sup>2</sup>Consorzio CREATE, 80125 Napoli, Italy

<sup>3</sup>CEA, IRFM, 13108 St. Paul-lez-Durance, France

<sup>4</sup>Eindhoven University of Technology, PO Box 513, 5600MB Eindhoven, The Netherlands

<sup>5</sup>CCFE/Fusion Association, Culham Science Centre, Abingdon, OX14 3DB, UK

<sup>6</sup>General Atomics, PO Box 85608, San Diego, CA 92186-5608, USA

<sup>7</sup>Joint Stock Company "D.V.Efremov Institute of Electrophysical Apparatus", St Petersburg, Russia

<sup>8</sup>National Research Centre "Kurchatov Institute", Moscow, Russia

<sup>9</sup>Max-Planck-Institut für Plasmaphysik, 85748 Garching, Germany

E-mail of Corresponding Author: [Joseph.Snipes@iter.org](mailto:Joseph.Snipes@iter.org)

The ITER Plasma Control System (PCS) has just completed its Preliminary Design [1], which includes detailed interfaces with the plant systems and control related diagnostics and operation from initial commissioning through 1<sup>st</sup> Plasma and early plasma operation in hydrogen and helium up to a plasma current of 15 MA in low confinement mode (L-mode) with moderate auxiliary heating power. The PCS architecture has been described in detail for this limited scope, but also is designed to be flexible enough to handle the more complex actuator sharing, exception handling, and advanced control functions that are required for high performance operation in deuteriumtritium plasmas [2]. Feasible schemes for magnetic control of the plasma current, position, and shape and kinetic control of gas and pellet fuelling, the electron cyclotron heating power for breakdown and burnthrough, and basic control of all three baseline heating systems including ion cyclotron and neutral beam heating have been demonstrated. Support functions for stray field topology and real-time plasma boundary reconstruction have been investigated including the dynamic effects of eddy currents in the conducting structures. Emergency plasma termination scenarios and the interactions with the central interlock system and the disruption mitigation system have been detailed. The resolutions of issues raised at the Preliminary Design Review regarding architecture complexity, required processing time for control schemes, intermediate final design reviews, and the implementation of complex investment protection functions will be discussed.

### References:

- [1] SNIPES, J.A., et al, Proc. 26th IAEA Fusion Energy Conference, Kyoto, Japan, October 2016, EX/P6-36 (International Atomic Energy Agency, Vienna), submitted to Nucl. Fus.
- [2] TREUTTERER, W., Proc. 29th Symposium on Fusion Technology, Prague, Czech Republic, September 2016, submitted to Fus. Eng. and Design.

## O-18: The preliminary architectural design of the ITER plasma control system

W. Treutterer<sup>1</sup>, G. Raupp<sup>1</sup>, J. Snipes<sup>2</sup>, P. de Vries<sup>2</sup>, D. A. Humphreys<sup>3</sup>, M. Walker<sup>3</sup>, G. de Tommasi<sup>4</sup>, M. Cinque<sup>4</sup>, S. Bremond<sup>5</sup>, P. Moreau<sup>5</sup>, R. Felton<sup>6</sup>

<sup>1</sup> *Max-Planck-Institut für Plasmaphysik, Boltzmannstraße 2, 85748 Garching, Germany*

<sup>2</sup> *ITER Organization, Route de Vinon sur Verdon, 13067 St Paul Lez Durance, France*

<sup>3</sup> *General Atomics, PO Box 85608, San Diego, CA 92186-5608, USA*

<sup>4</sup> *CREATE/Università di Napoli Federico II, Napoli, Italy*

<sup>5</sup> *Association CEA pour la Fusion Contrôlée, CEA Cadarache, 13108 St Paul les Durance, France*

<sup>6</sup> *CCFE Fusion Association, Culham Centre for Fusion Energy, Culham Science Centre, Oxfordshire, OX14 3DB, United Kingdom*

E-mail of Corresponding Author: [Wolfgang.Treutterer@ipp.mpg.de](mailto:Wolfgang.Treutterer@ipp.mpg.de)

The ITER Plasma Control System will be in charge of establishing, maintaining and varying plasma pulses with a plasma current up to 15 MA. The challenge of this process consists in the multitude of plasma and plant parameters to be controlled, as well as in the high power flows and in the plasma instabilities driven by non-linear physical effects that need to be contained to avoid damage to the machine. Correspondingly, the ITER Plasma Control System needs to execute a large and varying set of control functions, adapted to the actual state of the plasma. The functional architecture that enables this complex process has been developed in several stages following a System Engineering approach. Recently, the design passed the Preliminary Design Review [1], proving that the concepts developed earlier in [2] are suitable for first ITER plasma operation and beyond. The most important elements of the preliminary architecture, such as the compact controller class, which can dynamically change its properties, including the controlled variables, based on control mode commands from a central Pulse Supervision instance will be outlined. All control functions required for first plasma operation can be implemented with only 8 compact controllers. Exception handling, another important driver for architecture, is described in a separate contribution [3]. One of the most important tasks in this design was to contain the complexity of the system and find simple but powerful and flexible solutions. The ambivalence between system flexibility versus a potential exuberant growth in complexity of the PCS still gives rise to concerns. To address these concerns, typical use cases demonstrating how the degree of complexity is managed will be presented.

### References:

[1] SNIPES, J.A., et al, The Preliminary Design of the ITER Plasma Control System, this conference.

[2] TREUTTERER, W., et al, Architectural concept for the ITER Plasma Control System, FusEngDes 89 (2014), pp. 512–517

[3] RAUPP, G., et al, Exception Handling in the Preliminary Design of the ITER Plasma Control, this conference

## O-19: Exception handling in the preliminary design of the ITER plasma control

G. Raupp<sup>1</sup>, W. Treutterer<sup>1</sup>, G. Pautasso<sup>1</sup>, J.A. Snipes<sup>2</sup>, P.C. de Vries<sup>2</sup>, Y. Gribov<sup>2</sup>, M. Lehnen<sup>2</sup>, A. Winter<sup>2</sup>, L. Zabeo<sup>2</sup>, D. A. Humphreys<sup>3</sup>, M. Walker<sup>3</sup>, G. Ambrosino<sup>4</sup>, M. Cinque<sup>4</sup>, G.de Tommasi<sup>4</sup>, M. Mattei<sup>4</sup>, A. Pironti<sup>4</sup>, S. Bremond<sup>5</sup>, P. Moreau<sup>5</sup>, R. Nouailletas<sup>5</sup>, R. Felton<sup>6</sup>, F. Rimini<sup>6</sup> and the ASDEX Upgrade Team<sup>1</sup>

<sup>1</sup> *Max-Planck-Institut für Plasmaphysik, 85748 Garching, Germany*

<sup>2</sup> *ITER Organization, 13067 St Paul-lez-Durance, France*

<sup>3</sup> *General Atomics, PO Box 85608, San Diego, CA 92186-5608, USA*

<sup>4</sup> *Consorzio CREATE, 80125 Napoli, Italy*

<sup>5</sup> *CEA, IRFM, 13108 St. Paul-lez-Durance, France*

<sup>6</sup> *CCFE/Fusion Association, Culham Science Centre, Abingdon, OX14 3DB, United Kingdom*

E-mail of Corresponding Author: [gerhard.raupp@ipp.mpg.de](mailto:gerhard.raupp@ipp.mpg.de)

The ITER Plasma Control System (PCS) provides complex control functionality to adjust sets of plasma parameters for dedicated investigations, and combines this with exception handling functionality to optimize control, perform controlled shutdown procedures in critical situations, and assist the interlock system for investment protection.

Within this scope, the PCS has matured during the last few years to the preliminary design level and a design review was held in late 2016 [1]. While the focus of the physics analysis was to detail requirements on the initial commissioning, 1<sup>st</sup> plasma, and early plasma operation in H/He, the architecture design also addressed how to make sure that the PCS can be extended to control capabilities needed for advanced operation phases in DT [2].

The results of the use case analysis for exception handling in the PCS will be summarized. The required exception handling schemes and how they map to the PCS architecture and specific design choices and reviewer comments that are important to further develop the PCS exception handling functionality will also be presented.

### References:

[1] SNIPES, J.A. et al., The Preliminary Design of the ITER Plasma Control System, this conference

[2] TREUTTERER, W. et al., The Preliminary Architectural Design of the ITER Plasma Control System, this conference

## O-20: Preparing the PCS final design for ITER first plasma

P.C. De Vries<sup>1</sup>, J.A. Snipes<sup>1</sup>, L. Zabeo<sup>1</sup>, Y. Gribov<sup>1</sup>,  
A. Winter<sup>1</sup>, M.Y. Park<sup>1</sup>, W.C. Kim<sup>1</sup>, R. Yoshino<sup>1</sup> and F. Felici<sup>2</sup>

<sup>1</sup>*ITER Organization, Route de Vinon sur Verdon, 13067 St Paul Lez Durance, France.*

<sup>2</sup>*Eindhoven University, Faculty of Mechanical Engineering, P.O.Box 513, 5600MB,  
Netherlands*

E-mail of Corresponding Author: [Peter.Devries@iter.org](mailto:Peter.Devries@iter.org)

The preliminary design of the ITER Plasma Control System (PCS) was recently finalized [1]. This paper will detail preparation of the next stage, the PCS final design for integrated commissioning and ITER first plasma. This first plasma operation aims for the first fully integrated use of all basic Tokamak functions, creating a small plasma with a current of at least 100kA for at least 100ms and possibly up to 1MA lasting up to a few seconds. At this stage not all ITER systems will have been installed yet, and a limited set of diagnostics and actuators will be available. The PCS will act on the poloidal field coils via the power supplies, gas injection and Electron Cyclotron Heating to assist with the plasma initiation.

Although only a limited set of control functions will be required, the design, implementation and first utilization of the ITER plasma control system will be a great challenge. Firstly, the final design description of the individual controllers and event handling, actuator and sensor models, need to be provided, including thorough modelling of relevant use-cases, for which the ITER PCS Simulation Platform will be used [2]. Some of the use-cases will be those describing the plant system commissioning, others the actual first plasma operations. The design development and description should facilitate a straightforward implementation and minimise errors. Secondly, the final design should detail the plans for deployment. How is each controller going to be commissioned, in conjunction with the necessary plant system commissioning itself? These plans should include the validation of a number of plant models, such as, passive components, vessel, magnetic diagnostics, power supplies, used for the controller and event handling design. This will also support the PCS development for the subsequent operations phase. Thirdly, the deployment plans will set requirements and procedures for system tuning and optimization, yielding a customization of the operator interfaces as well as commissioning procedures. The staged approach to bring the ITER plant up to full performance, will require the PCS to be upgraded with new control functions and commissioned at each stage, and the first plasma operations stage will have to show that the implementation, commissioning and deployment procedures run smoothly.

### References:

[1] SNIPES, J.A., et al., Overview of the Preliminary Design of the ITER Plasma Control System (IAEA FEC, Kyoto, Japan, 2017)

[2] WALKER, M.L., et al., Fus. Eng. Des. 96-97 (2015) 716.



## O-21: Investigation of methods for mitigating influences of magnetic measurement noises on equilibrium control in JT-60SA

Y. Miyata, T. Suzuki, S. Ide, H. Urano, G. Matsunaga, M. Takechi and H. Kubo

*Fusion Energy Research and Development Directorate, National Institutes for Quantum and Radiological Science and Technology, Naka, Ibaraki, Japan*

E-mails of Corresponding Authors: [miyata.yoshiaki@qst.go.jp](mailto:miyata.yoshiaki@qst.go.jp), [suzuki.takahiro@qst.go.jp](mailto:suzuki.takahiro@qst.go.jp),  
[ide.shunsuke@qst.go.jp](mailto:ide.shunsuke@qst.go.jp), [urano.hajime@qst.go.jp](mailto:urano.hajime@qst.go.jp), [matsunaga.go@qst.go.jp](mailto:matsunaga.go@qst.go.jp),  
[takechi.manabu@qst.go.jp](mailto:takechi.manabu@qst.go.jp), [kubo.hiroataka@qst.go.jp](mailto:kubo.hiroataka@qst.go.jp)

Precise control of the plasma equilibrium is essential for safe and stable plasma operation. An MHD equilibrium control simulator (MECS) has been developed in order to study plasma equilibrium control in JT-60SA [1]. The MECS consists of modules of plasma simulator, plasma shape reconstructor, and equilibrium controller to simulate the plasma equilibrium control. The plasma simulator predicts the plasma equilibrium consistent with eddy current induced in the conducting structures such as the vacuum vessel and the stabilizing plate under conditions of given coil currents and plasma internal parameters. The MECS adopts the ‘ISOFLUX’ control scheme for the control of plasma position and shape, in which the controller modifies the poloidal field coil currents to decrease the differences between poloidal magnetic flux at the last closed flux surface and that at the control points which determine the target plasma position and shape. The MECS adopts the Cauchy Condition Surface (CCS) method for the plasma shape reconstruction. The CCS method estimates the plasma boundary from the magnetic measurement signals and provides the residual required for the plasma position and shape control [2].

Noises of magnetic measurement signals have influences on the plasma equilibrium control in real tokamak devices. The fluctuation of the residual required for the plasma position and shape control due to the measurement noises makes the over voltage command values of PF coil power supplies. Since the rated voltages of the base power supplies are approximately  $\pm 1$  kV in JT-60SA, the influences of measurement noises on the plasma equilibrium control should be mitigated in order to achieve a stable plasma operation within the machine specifications. Possible mitigation methods include: (i) Application of digital low-pass filter to magnetic measurement signals. (ii) Optimization of the control matrix for avoiding the ill-conditioned problems. (iii) Optimization of setting parameters in CCS method for avoiding the ill-conditioned problems. The effectiveness and characteristics of their methods is being analyzed using MECS. It has been found that the maximum value of the time constant of digital low-pass filter that the plasma vertical position can be controlled decreases with increases in elongation of plasma cross-section and plasma current profile parameter  $l_i$  and decrease in the plasma pressure parameter  $\beta_p$ . The region of growth rate of vertical instability expected in the JT-60SA operation is assessed using MECS, and the appropriate time constant is determined so as to be able to take full control of the plasma that has the maximum growth rate of vertical instability. The analysis results will be reported in this paper.

### References:

- [1] MIYATA, Y. et al., “Study of Plasma Equilibrium Control for JT-60SA using MECS”, Plasma and Fusion Research 9, 3403045 (2014).
- [2] KURIHARA, K., “A new shape reproduction method based on the Cauchy-condition surface for real-time tokamak reactor control”, Fusion Engineering and Design 51-52, 1049 (2000).



## **O-22: Implementation of the on-line density limit disruptions prediction and avoidance system based on neural networks**

Wei Zheng<sup>1,2</sup>, Feiran Hu<sup>1,2</sup>, Ming Zhang<sup>1,2</sup>, Xueqing Zhao<sup>1,2</sup>, Yinan Zhou<sup>1,2</sup>, Peng Shi<sup>1,2</sup>,  
Yunong Wei<sup>1,2</sup>, Zhongyong Chen<sup>1,2</sup>, Yuan Pan<sup>1,2</sup>

<sup>1</sup>*State Key Laboratory of Advanced Electromagnetic Engineering and Technology in Huazhong University of Science and Technology, Wuhan 430074, China*

<sup>2</sup>*School of Electrical and Electronic Engineering in Huazhong University of Science and Technology, Wuhan 430074, China*

E-mail of Corresponding Author: [zhangming@hust.edu.cn](mailto:zhangming@hust.edu.cn)

Density limit disruptions remain an important issue for tokamaks, the density limit disruption prediction and avoidance system is the key to solving the problem. In previous research [1], a density limit predictor based on artificial neural network has been developed. It performs well off-line, but it is not original designed for working in real time. In order to predict and avoid density limit disruption on-line (synchronous with discharging), we redesign the whole system. We reconstitute the structure of the network and add the function of density prediction, transform from 3-layer BP network to a hybrid structure. We also re-choose the input diagnostic signals without affecting the performance for real time purposes. The new network takes advantage of the new inputs, new structure and optimized training method to obtain better performance. In order to predict disruption in real time, we port the trained network to the LabVIEW-RT platform and integrate it to the new developed real time density feedback system based on J-TEXT POLARIS [2]. The system can not only predict but also avoid density limit disruption using density feedback control. The whole system has installed on J-TEXT and the on-line result will be present in the paper.

### **References:**

- [1] WANG, S.Y., CHEN, Z Y, et al., Plasma Phys. Control. Fusion. 58 055014 (2016).
- [2] CHEN, J., ZHUANG, G., et al., Rev. Sci. Instrum. 85, 11D303 (2014).

## **O-23: Neural network based real-time reconstruction of KSTAR magnetic equilibrium and imputation with Bayesian scheme**

Semin Joung<sup>1</sup>, Sehyun Kwak<sup>1</sup>, Y.M. Jeon<sup>2</sup>, S.H. Hahn<sup>2</sup>, H.S. Han<sup>2</sup>, H.S. Kim<sup>2</sup>, J.G. Bak, S.G. Lee and Y.-c. Ghim<sup>1</sup>

<sup>1</sup>*Department of Nuclear and Quantum Engineering, KAIST, Daejeon 34141, S. Korea*

<sup>2</sup>*National Fusion Research Institute, Daejeon, S. Korea*

Controlling the fusion-grade plasmas for tokamak operation requires observation of real time plasma position and shape which can be estimated using Grad-Shafranov solver such as EFIT [1]. Since off-line EFIT is, in general, computationally intensive, obtaining quality of off-line EFIT results in real time is challenging. Thus, we develop a neural network trained with the database which contains magnetic signals and off-line EFIT results from KSTAR as inputs and targets, respectively. Drifts in the magnetic signals are pre-processed based on Bayesian scheme [2] which can be performed in real time. The network with two hidden layers with 30 and 20 nodes for each layer is used and shown to provide reliable outputs up to 20% of input errors. Furthermore, Gaussian process [3] based imputation scheme has been developed such that the neural network can reconstruct the magnetic equilibrium with a few of missing inputs. This imputation scheme has been developed based on the Bayesian probability whose likelihood is determined based on the Maxwell's equations. We note that the developed neural network is yet to be implemented for KSTAR real time operation.

### **References:**

- [1] LAO, L.L., et al., Nucl. Fusion. 25, 1611 (1985).
- [2] SIVIA, D., SKILLING, J., "Data Analysis: A Bayesian Tutorial", Oxford science publications (2006).
- [3] RASMUSSEN. C.E., WILLIAMS, C.K.I., "Gaussian Processes for Machine Learning", MIT Press (2006).

## O-24: GPU based optimal control techniques for resistive wall mode (RWM) feedback in tokamaks

Mitchell Clement<sup>1</sup>, Jeremy Hanson<sup>2</sup>, and Gerald Navratil<sup>2</sup>

<sup>1</sup>*Mechanical and Aerospace Engineering, University of California, San Diego, La Jolla, CA 92093, USA*

<sup>2</sup>*Department of Applied Physics and Math, Columbia University, New York, NY 10027, USA*

E-mails of Corresponding Author: [mdclemen@eng.ucsd.edu](mailto:mdclemen@eng.ucsd.edu)

The DIII-D tokamak can excite strong, locked or nearly locked kink modes whose rotation frequencies do not evolve quickly and are slow compared to their growth rates. To control these Resistive Wall Modes (RWMs), DIII-D and Columbia University have installed a GPU-based feedback control system in a low-latency architecture based on a system developed on the HBT-EP tokamak [1]. This system is capable of handling up to 96 inputs and 32 analog outputs with microsecond latency. Simulations have predicted that modern control techniques like Linear Quadratic Gaussian (LQG) control will perform better than classical control techniques when using control coils external to the vacuum vessel. The VALEN RWM model [2] has been used to gauge the effectiveness of RWM control algorithms in tokamaks. VALEN models the perturbed magnetic field from a single MHD instability and its interaction with surrounding conducting structures as a series of coupled circuit equations. An LQG control algorithm based on VALEN has been developed and tested on this GPU based system. An overview of the control hardware, VALEN model, control algorithm and results of experiments to develop control of a rotating  $n=1$  perturbation using external coils will be presented. Results from high  $\beta_N$  experiments also suggest that advanced feedback techniques using external control coils may be as effective as internal control coil feedback using classical control techniques.

### References:

- [1] RATH, N. et al. Adaptive control of rotating magnetic perturbations in HBT-EP using GPU processing. *Plasma Physics and Controlled Fusion*, 55(8):084003, 2013.
- [2] BIALEK, J. et al. Modeling of active control of external magnetohydrodynamic instabilities. *Physics of Plasmas*, 8(5):2170–2180, 2001.

*Work supported by the U.S. DOE under DE-FC02-04ER54698 and DE-FG02-04ER54761.*

## O-25: Microprocessor-based digitizers combined with preamplifiers and detectors as a solution for EMI suppression in U-3M

M.B. Dreval, F.I. Ozherelyev

IPP NSC Kharkov Institute of Physics and Technology, Kharkov, Ukraine

E-mail of Corresponding Author: [mdreval@kipt.kharkov.ua](mailto:mdreval@kipt.kharkov.ua)

Electromagnetic interference (EMI) has become a major problem for circuit designers, especially in the case of tokamaks and stellarators. A strong 8-9 MHz noise from the RF plasma heating generators forms additional difficulties in the diagnostic signal measurements in the U-3M torsatron compared with other stellarators and tokamaks. Measurements of the rather low intensity of the plasma emission from the low-density plasma ( $n_e=10^{10}\text{ cm}^{-3}$ ) are necessary when studying the initial stage of the RF discharges, that is of current importance for U-3M [1]. A rather high temporal resolution of this diagnostics is need for the U-3M plasma fluctuations studies. Set of new optical diagnostics (20-channels SXR and bolometers, 12- channels  $H_\alpha$ ) with a temporal resolution of up to 4 microseconds has been designed and is successfully used in the noisy U-3M plasma conditions in studies of the breakdown plasma and plasma fluctuations. In the original electronics design all the diagnostics components, including the STM-32-microprocessor-based data acquisition system, are assembled in a single unit (without analog signals or digital interface wires), as it is shown in Figure 1.

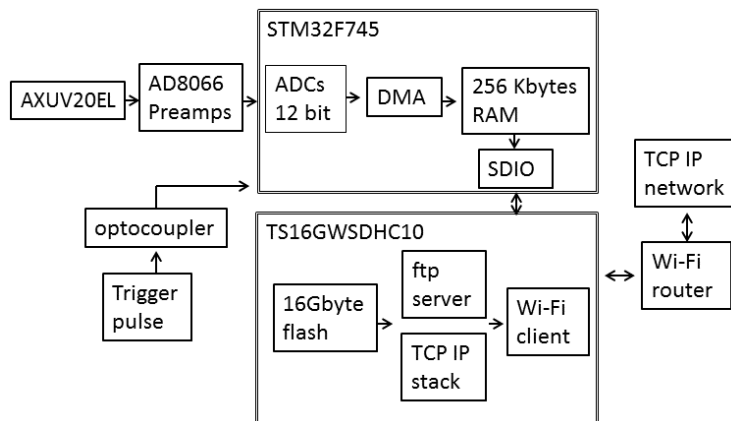

Figure 1: Diagram of the diagnostic electronics.

This design allows one to prevent the ground loop interference, to remove the RF load on diagnostics components and to increase substantially the system protection from different electromagnetic noises. This diagnostics can be easily converted to the fast control part of some feedback systems owing to set of digital-to-analog converters and digital outputs available in STM-32, and owing to real time data processing via available direct memory access interfaces.

### References:

- [1] DREVAL, M.B., *et al.*, Rev. Sci. Instrum. **87**, 073503 (2016)

## O-26: Online processing of large volume experimental data in strong electromagnetic and radiation fields in ITER neutron diagnostics

I.Semenov<sup>1</sup>, A.Khilchenko<sup>2</sup>, V.Vorobev<sup>1</sup>, V.Golachev<sup>1</sup>, S.Portone<sup>1</sup>, E.Mironova<sup>1</sup>, D. Nikolaeva<sup>1</sup>

<sup>1</sup>*“Project Center ITER”, Russia, Moscow, sq. Academic Kurchatov, 1 b.3*

<sup>2</sup>*BINP, Russia, Novosibirsk, prosp. Academic Lavrentiev 11*

E-mail of Corresponding Author: [I.Semenov@iterf.ru](mailto:I.Semenov@iterf.ru)

ITER plasma diagnostics have tens of broadband (~0-500 MHz and more) measurement channels. These multi-channel diagnostics systems generate data flow ~100 Gb/sec, which is transferred to Plasma Control System (PCS) in real time.

Besides, design of diagnostic acquisition systems must satisfy special environment requirements: some sensors, actuators and front-end electronics equipment is located close to ITER Vacuum Vessel in Port plugs, Port Cells, Galleries and must work in strong magnetic (~0.4 Tesla), neutron (~  $10^7$  n.cm<sup>-2</sup>.s<sup>-1</sup>), and Hard X-ray fields. In addition, this equipment located near megawatt radiofrequency oscillators (up to 170 GHz) and must have good high-frequency electromagnetic compatibility. In some cases, this equipment cannot be relocated outside harsh environment because of long copper cables from sensors or preamplifiers induce noises on experimental signals. The most serious problem is strong radiation during ITER operation, which leads to damage of the most sensitive electronics parts. In ITER the number of different electronics parts in radiation zone is very large ~500, compared with about 20-50 different parts in ATLAS detector. Radiation spectrum of thermonuclear plasma is different from Space and LHC radiation. Development of special radiation-hard electronics parts for ITER is very expensive and not appropriate for the project.

Network infrastructure is another limitation for data acquisition systems. Some plasma diagnostics generate huge amount of experimental data, which is transmitted to PCS in real time. It is necessary to organize data flow with the data transmission velocity more than 10 times higher the channel capacity of existing ETHERNET and computer buses (~10-50 Gb/sec).

Moreover, for PCS it is necessary to take into account not only data transmission velocity, but also jitter, latency and packets collision between plant systems and between plant system and supervisor. All above-mentioned issues require optimization of data acquisition architecture in general.

Report presents data acquisition system developed for Russian ITER neutron diagnostics, which satisfy quality requirements (for QC3 and QC4 equipment). Main features of this system are:

- external block with front-end electronics, designed as Faraday casing, is placed in ITER Port Cell, in shielded cabinet; it contains minimum electronic components.
- main block placed in protected zone at the distance ~100 m.
- main and external equipment are connected by multi-channel digital optical lines (48Ch x 10Gb/sec=480 Gb/s).

Preliminary data processing implemented in main block with smart ADCs (250-500 MHz step, 14 bit, FPGA) and primary data processing is performed inside main block in FPGA, IPC CPU and in local cluster (NvidiaTESLA S1070). System uses data compression and fits the size of the data flow to the Time Communication Networks (TCN) bandwidth ~10 Gb/sec.

## O-27: A Framework for the integration of Linux FPGA SoC devices

A. Rigoni, G. Manduchi<sup>1</sup>, C. Taliercio<sup>1</sup>, A. Luchetta<sup>1</sup> and T. Schröder<sup>2</sup>

<sup>1</sup> *Consorzio RFX (CNR, ENEA, INFN, Università di Padova, Acciaierie Venete SpA), Padova, Italy*

<sup>2</sup> *Max-Planck-Institut für Plasmaphysik, D-17491 Greifswald, Germany*

E-mail of Corresponding Author: [andrea.rigoni@igi.cnr.it](mailto:andrea.rigoni@igi.cnr.it)

System on Chip (SoC) is a hardware solution combining different hardware devices in the same chip. In particular, the XILINX Zinq solution, implementing an ARM processor and a configurable FPGA on the same chip, is a candidate technology for a variety of applications of interest in fusion research, where FPGA fast logic must be combined with a processor for high level functions and communication. Developing Zinq based applications requires (1) the development of the FPGA logic using the XILINX Vivado IDE, (2) mapping information between the FPGA device and the processor address space, (3) developing the kernel drivers for interacting with the FPGA device and (4) developing the high level application programs in user space for the supervision and the integration of the system.

The paper presents a framework that integrates all the above steps and greatly simplifies the overall process. In particular, the framework will:

- Supervise the compilation of the Linux kernel from the XILINX repository;
- Handle the management of the VIVADO project and of the required Intellectual Property (IP) components that are required for FPGA integration;
- Supervise the building of the Device Tree structure required for the proper mapping of the FPGA device(s) in the processor address space;
- Provide templates for the development of the required Linux drivers;
- Provide tools for the development of high level functions in user space.

All the information handled by the framework is mapped into a git repository so that the project can be shared among different teams.

The presented framework has been used for the development of a programmable timing device in W7X. The development of new devices integrating data acquisition and timing functions is foreseen for RFX-Mod.

## **O-28: Continuous acquisition and storage of Wendelstein 7-X data**

A. Holtz<sup>1</sup>, T. Bluhm<sup>1</sup>, M.Grahl<sup>1</sup>, M. Grün<sup>1</sup>, C. Hennig<sup>1</sup>, J. Krom<sup>1</sup>, G. Kühner<sup>1</sup>, H. Laqua<sup>1</sup>, M. Lewerentz<sup>1</sup>, H. Riemann<sup>1</sup>, A. Spring<sup>1</sup>, A. Werner<sup>1</sup> and the W7-X Team<sup>1</sup>

*Max Planck Institute for Plasma Physics, Wendelsteinstraße 1, D-17491 Greifswald, Germany*

The main goal of the Wendelstein 7-X experiment is to investigate the ability of a stellarator to sustain a fusion relevant plasma over a long period of time. High resolution measurement data have to be acquired and stored continuously during plasma experiments planned with up to 30 minutes duration. Machine data have to be archived uninterrupted during the whole operation phases over several months. Beyond this, external and analysis data are to be uploaded between experiments.

Thus, continuous acquisition and storage of data on different time scales and bandwidths are one of the main challenges of the W7-X CoDaC framework. As a result of the commissioning and the first operation phase of W7-X the basic archive system architecture has been qualified successfully: the data archive system has been running continuously for more than two years.

This contribution gives a global overview of the W7-X archive architecture: from data collection over data storage to answering user requests. The requirements which derive from the different use cases for machine control and the needs of the physicists are discussed. The technical and scientific concepts to design a system with high bandwidth and storage capability but low read-after-write latency are presented and compared to other big projects and world ventures like the Large Hadron Collider or Facebook.

## O-29: Next generation web based live data monitoring for W7-X

Simon Dumke, Heike Riemann, Torsten Bluhm, Robil Daher, Michael Grahl, Martin Grün, Andreas Holtz, Jon Krom, Georg Kühner, Heike Laqua, Marc Lewerentz, Anett Spring, Andreas Werner and the W7-X team

*Max Planck Institute for Plasma Physics, Greifswald, Germany*

The Wendelstein 7-X experimental stellarator differs from most other fusion experiments in one respect: Instead of relatively short pulses for which measured data can be stored locally during the experiment, then collected centrally and analyzed afterwards, W7-X aims for steady state operation and already works with multiple pulses in close succession. This results in many special project requirements – one of them being continuous acquisition of measurement data, a significant portion thereof even 24/7. Due to the differing scenario, this flood of data cannot be stored locally at the place of acquisition for handling after the experiment. It has to be distributed over computer networks for both storage and inspection – immediately and continuously. Being able to monitor this data in near real time is a central need for both scientific experimenters and responsible personnel.

During such a live data monitoring, the group of end users is quite varying in respect to numbers of clients, diversity and numbers of monitored data signals as well as use cases and usage environments. Combined with an ever growing number of targeted client tool platforms from desktop computers and various mobile devices to large-scale control center video wall installations, the need arises for a network-based, platform independent data monitoring architecture. The resulting system has to be reliable, highly scalable (for future long term experiments ideally even *during* a measurement session), light and unobtrusive on the network infrastructure and to offer users a maximum of flexibility in usage and platform support. In addition, international cooperation brings the requirement for remote participation capabilities.

To meet these demands, the Control, Data Acquisition and Communication Group (CoDaC) at W7-X developed and implemented the new data monitoring architecture described in this poster, comprising four primary components:

- **Centralized knowledge:** A central repository of knowledge about all available data signals;
- **Distributed acquisition:** A specialized data source component for the on-site data acquisition framework;
- **Flexible distribution:** A runtime-scalable, stackable network of data multiplexers, managing client subscriptions;
- **Comfortable access:** A highly flexible client web application allowing subscription and visualization of measured data signals, events, experiment progress etc.

To be integrated with the existing centrally managed W7-X CoDaC software runtime environment CoDaStation, the first three components (servers of this client-server architecture) are based on the Java stack, while the client side interface tries for maximized user experience using modern web technologies like JavaScript, jQuery, web sockets and WebGL.



### O-30: Study of data statistics and retrieval for EAST MDSplus data system

F. Wang<sup>1</sup>, Y.T. Wang<sup>1,2</sup>, Y. Chen<sup>1</sup>, S. Li<sup>1</sup>, and F. Yang<sup>1,2</sup>

<sup>1</sup>*Institute of Plasma Physics, Chinese Academy of Sciences, Hefei, Anhui, China,*

<sup>2</sup>*University of Science and Technology of China, Hefei, Anhui, China,*

<sup>3</sup>*Department of Computer Science, Anhui Medical University, Hefei, Anhui, China*

E-mail of Corresponding Author: [wangfeng@ipp.ac.cn](mailto:wangfeng@ipp.ac.cn)

A large distributed data acquisition system based on PXI/PXIe technology has been implemented on EAST tokamak. Now the whole data system has more than 60 data acquisition units and more than 2500 raw channels, and the maximum data throughput is about 5GBytes/s. All the acquired data are continuously stored into MDSplus<sup>[1]</sup> database, moreover the calculated and analysed data are also saved into MDSplus. In case of long-term discharge mode, the raw data of one shot is more than 1TBytes, and the total data of one campaign is more than 100TBytes.

MDSplus is helpful to store tokamak experiment discharge data, and the scientific data are saved into database by shot and tree, and it is easy to know the signal information of one shot or tree. However, it is difficult to get the general metadata information of all the shots and trees. Even if we can read the information by some scripts, but it is not so convenient and the data retrieval speed is slow. So we have planned to design a data statistics and retrieval system for EAST MDSplus data system, which can provide all the metadata information of all the trees such as signal name, sampling rate, data size, data available or not, and so on, basing on these metadata the system can give detailed statistics and reports automatically by some pre-defined model, which can help users to grasp the status and schema of all the data. The system has been developed based on apache/mysql/php framework and the PCIe SSD storage is adopted to promote the database access speed. The design details will be given in the paper.

#### References:

[1] MDSplus, <http://mdsplus.org>

## O-31: ITER Unified Data Access (UDA)

R. Castro<sup>1</sup>, Y. Makushok<sup>2</sup>, L. Abadie<sup>3</sup>, S. Pinches<sup>3</sup>, D. G. Muir<sup>4</sup>, J. Hollocombe<sup>4</sup>, J. Vega<sup>1</sup>,  
J. Faig<sup>5</sup>, G. García<sup>2</sup>

<sup>1</sup>*Laboratorio Nacional de Fusión, CIEMAT. Av. Complutense 40. 28040 Madrid. Spain*

<sup>2</sup>*SGENIA C/Chile, 4 Edificio II. Las Rozas. Madrid. Spain*

<sup>3</sup>*ITER Organization, St Paul lez Durance, France*

<sup>4</sup>*EURATOM/UKAEA Fusion Association, Culham Science Centre, Abingdon, Oxfordshire UK*

<sup>5</sup>*INDRA Sistemas, S.A. Unid. de Sist. de Control. Dirección de Tecn. Energética, Madrid, Spain*

E-mail of Corresponding Author: [rodrigo.castro@ciemat.es](mailto:rodrigo.castro@ciemat.es)

All data that are going to be archived at ITER requires a data access solution that provides an effective, flexible and homogeneous method to access and retrieve archived data. In order to provide this functionality, UDA (Unified Data Access) system has been implemented and has been included in the last version of ITER CODAC Core System [1]. ITER will produce a lot of data (a few PB/day) [2][3]. ITER data is also planned to be accessed by many concurrent users. Thus it is essential to demonstrate full scalability of UDA.

UDA aims at providing a unified data access for archived data produced by both continuous and pulsed systems. It also hides the storage nature from users.

### References:

[1] DI MAIO, F., “CODAC Core System Overview”,

[http://static.iter.org/codac/cs/CODAC\\_Core\\_System\\_Overview\\_34SDZ5\\_v5\\_3.pdf](http://static.iter.org/codac/cs/CODAC_Core_System_Overview_34SDZ5_v5_3.pdf) (2016)

[2] ABLA, G., et al., “ITERDB—The Data Archiving System for ITER”, Fusion Engineering and Design, Volume 89, Issue 5, Pages 536-541 (2014)

[3] CASTRO, R., et al., “Data archiving system implementation in ITER's CODAC Core System”, Fusion Engineering and Design, Volumes 96–97, Pages 751-755. (2015)

## **O-32: Evaluation of the ITER Data archiving network API on the DIII-D tokamak**

B. Penaflor, D. Piglowski, C. Liu, F. Garcia, D. Miller (General Atomics), L. Abadie (ITER)

*General Atomics, P.O. Box 85608, San Diego, California 92186-5608, USA*

*ITER, 13067 St Paul Lez Durance Cedex, France*

E-mail of Corresponding Author: [penaflor@fusion.gat.com](mailto:penaflor@fusion.gat.com)

The systems responsible for the archival and access of data at ITER will play a critical role from the very start of tokamak operations. Ensuring the readiness of the software being developed to handle the large amounts of data to be streamed to the archive systems will be of great importance and require extensive testing. To assist in this validation DIII-D offers the flexibility and means for testing on an operational tokamak. Because of the extensive experience gained in supporting data archiving and retrieval for a large and varied set of diagnostics and in-house expertise in Linux based systems DIII-D is able to provide a uniquely qualified test platform to fully exercise ITER's software. In this paper, we report on the work that was recently performed to setup a data acquisition and archiving test system connected to live diagnostics for the purpose of evaluating the performance and completeness of the ITER Data Archiving Network Application Program Interface (DAN API). Diagnostic data that was made available and examined for archiving into the ITER DAN included data such as plasma current, bolometry, electron density, soft x-ray signals, visible camera images, data from the Thomson scattering and Electron Cyclotron Heating (ECH) systems. The hardware used for the test system was comprised of two high performing archiver computers and two data acquisition streamer computers. The archiver nodes were configured with 64 GB of RAM and 1 TB of fast solid state drive storage, and networked to the acquisition computers in a local 10 Gb/s network. This configuration was chosen in order to push performance limits and test data streaming and archiving to the ITER DAN at rates of up to 1 Gb/s from multiple archive sources. This material is based upon work supported by ITER under contract number 4300001226. The DIII-D facility where this work was performed is supported by the US DOE under DE-FC02-04ER54698.

### **O-33: MDSplus Yesterday, today and tomorrow**

T.Fredian<sup>1</sup>, J. Stillerman<sup>1</sup>, G. Manduchi<sup>2</sup>, A. Rigoni<sup>2</sup>, K. Erickson<sup>3</sup>, T. Schröder<sup>4</sup>

*Massachusetts Institute of Technology, Cambridge, MA, USA*

*Consorzio RFX, Euratom-ENEA Association, Corso Stati Uniti 4, Padova 35127, Italy*

*Princeton Plasma Physics Laboratory, Princeton, NJ 08543, USA*

*Max-Planck-Institut für Plasmaphysik, D-17491 Greifswald,, Germany*

E-mail of Corresponding Author: [twf@psfc.mit.edu](mailto:twf@psfc.mit.edu)

MDSplus is a data acquisition and analysis system used worldwide predominantly in the fusion research community. Development began 31 years ago by a collaboration of software developers who were charged with providing a data acquisition system for three new fusion experiments under construction: CMOD at MIT, ZTH at LANL and RFX at Padova, Italy. The design of MDSplus combined the functionality of the original MDS data system developed at MIT for the Alcator fusion experiment with new features suggested by the developers from the other laboratories. The development of MDSplus used a RAD (rapid application development) approach before RAD became a mainstream methodology. MDSplus was implemented and ready for the initial operation of CMOD in 1991. Since that time many other fusion facilities started using MDSplus for data acquisition and/or for exporting their data to other sites. Today MDSplus is still used around the world for fusion energy research. Work on MDSplus continues to enhance its capabilities, support more platforms and to improve its reliability. It is anticipated that MDSplus will continue to provide valuable tools for the fusion energy research community. This paper is to describe some of the history of the MDSplus software, the work that is currently underway and the plans to enable MDSplus to continue to be available and supported long into the future.

## **O-34: Hierarchical dynamic containers for fusion data**

David Fridrich, Jakub Urban

*Institute of Plasma Physics of the CAS, Za Slovankou 1782/3, 182 00 Prague 8, Czech Republic*

E-mail of Corresponding Authors: [fridrich@ipp.cas.cz](mailto:fridrich@ipp.cas.cz), [urban@ipp.cas.cz](mailto:urban@ipp.cas.cz)

Scientific data can be naturally organized into hierarchical tree structures. One can find several examples of such a hierarchy, for example XML or JSON for general purpose and specifically HDF5 for scientific data. Data types in the EU-IM and IMAS frameworks are also organized into trees. Similarly, experimental data from fusion experiments have tree structures. We propose a new data communication platform that is well suited for experimental data and well as integrated modelling. This effort is part of our “Data Access and Provenance tools for the exploitation of EUROfusion experiments project” EUROfusion Engineering Grant.

Our Hierarchical Dynamic Containers (HDC) library provides a similar functionality for in-core, shared memory communication as HDF5 does for files. Thus, the library enables fast yet easily manageable data exchange within multiple numerical codes (typical examples are integrated modelling workflow actors). HDC enables a zero data copy mechanism even across programming languages. The tree structure is built around key-value storages, managed by a plugin system. Thus users can choose from a variety of existing solutions of the underlying storage, including private, shared or distributed memory or persistent files.

The core library is written in C++11, highly leveraging the Boost library, and provides bindings for C, Fortran and Python (other languages are foreseen). The intent is to provide a clean, simple and universal API. HDC is planned to be used in IMAS and for COMPASS, JET, MAST-U and TCV databases.

## O-35: Distributed Database based Data Storage and Manage System for Future Fusion Experiment

W. Zheng<sup>1,2</sup>, Q. Liu<sup>1,2</sup>, M. Zhang<sup>1,2</sup>, K. Wan<sup>1,2</sup>, F. Hu<sup>1,2</sup>, and K. Yu<sup>1,2</sup>

<sup>1</sup> *State Key Laboratory of Advanced Electromagnetic Engineering and Technology, Huazhong University of Science and Technology, Wuhan 430074, China*

<sup>2</sup> *School of Electrical and Electronic Engineering, Huazhong University of Science and Technology, Wuhan 430074, China*

E-mail of Corresponding Author: [zhangming@hust.edu.cn](mailto:zhangming@hust.edu.cn)

As fusion experimental goes to steady state and high-performance data acquisition system been developed, traditional storage solutions cannot cope with the needs of fusion experiment data storage. Parallel file systems such as Lustre are being adopted by more and more facilities [1-4]. The scaling-out of performance and capacity features addressed the main issue of traditional SAN based storage. However, traditional file system based software solutions are still being used with the parallel file system [2, 5]. They lack modern data manage functions and limiting the performance of parallel storage. J-TEXT Cloud Database (JCDB) is a software stack that uses distributed database to provide fusion experiment data storage and management services[6]. It ships with a storage engine powered by Cassandra database. This storage engine is specifically designed for fusion experiment data and provides great performance. Data is divided into chunks when written and stored in a specially designed distributed database across the cluster. It has a MongoDB powered metadata management system which works seamlessly with the storage engine. JCDB is fully modular, handling different data type and metadata management functions are integrated as plug-ins. Even the storage engine can be changed. JCDB has the benefit of parallel file systems, provides complex metadata manage functions and comes with great performance.

### References:

- [1] NAKANISHI, H., et al., Fusion Eng. Des., vol. 89, pp. 707-711, 2014.
- [2] PÍSAČKA, J., et al., Fusion Eng. Des., vol. 87, pp. 2238-2241, 2012.
- [3] IANNONE, F., et al., Fusion Eng. Des., vol. 87, pp. 2063-2067, 2012.
- [4] NAKANISHI, H., et al., Nucl. Fusion, vol. 51, p. 113014, 2011.
- [5] CASTRO, R., et al., Fusion Eng. Des., vol. 96-97, pp. 751-755, 2015.
- [6] ZHANG, M., et al., Fusion Eng. Des., vol. 112, pp. 1003-1006, 2016.

## **O-36: TokSearch: A search engine for fusion experimental data**

B.S. Sammuli, J.L. Barr, N.W. Eidietis, K.E.J. Olofsson, S.M. Flanagan, M. Kostuk, D.A. Humphreys

*General Atomics, 3550 General Atomics Ct, San Diego CA, USA*

E-mail of Corresponding Author: [sammuli@fusion.gat.com](mailto:sammuli@fusion.gat.com)

At a typical fusion research site, experimental data is stored using archive technologies that deal with each discharge as an independent set of data. These technologies (e.g. MDSplus or HDF5) are typically supplemented with a relational database that aggregates metadata for multiple shots to allow for efficient querying of certain predefined quantities. Often, however, a researcher will need to extract information from the archives, possibly for many shots, that is not available in the relational database or otherwise indexed for quick retrieval. To address this need, a new search tool called TokSearch has been added to the General Atomics TokSys control design and analysis suite. This tool provides the ability to rapidly perform arbitrary, parallelized queries of archived tokamak shot data (both raw and analysed) over large numbers of shots. The TokSearch query API borrows concepts from SQL, and users can choose to implement queries in either Matlab<sup>TM</sup> or Python. Searches can be performed in both batch and interactive modes.

TokSearch is designed to flexibly interchange its underlying parallelization technology. Currently the Python API supports Apache Spark<sup>TM</sup>, which is a cluster-computing framework that runs on commodity hardware. The Matlab API supports use of both the Matlab Parallel/Distributed Computing toolbox and Spark.

An initial implementation of TokSearch has been deployed at DIII-D, and we highlight some examples of TokSearch usage there. One such example is the traversal of tens of thousands of shots to identify disruptions and classify those disruptions according to heuristics provided by TokSys. Another example is the use of TokSearch to quickly cache a set of signal data into cluster memory so that iterative machine learning exploration can be done. We demonstrate linear scaling of the processing throughput when rerunning these queries using a varying number of CPU cores.

Additionally, we outline a roadmap for both hardware and software enhancements that allow for increased usability and scaling, as well as application to next-generation tokamaks including ITER.

*This work was supported by General Atomics internal research and development funds.*

## **O-37: Navigational data management**

J. Stillerman, M. Greenwald and J. Wright

*Massachusetts Institute of Technology, Cambridge, MA, 02139 USA*

E-mail of Corresponding Author: [jas@mit.edu](mailto:jas@mit.edu)

Modern science generates large complicated heterogeneous collections of data. In order to effectively exploit these data, researchers must be find relevant data, and enough of its associated metadata to understand it and put it in context. This problem exists across a wide range of research domains and is ripe for a general solution.

Existing ventures address these issues using ad-hoc purpose-built tools. These tools explicitly represent the data relationships by embedding them in their data storage mechanisms and in their applications. While producing useful tools, these approaches tend to be difficult to extend and data relationships are not necessarily traversable symmetrically.

We are building a general system for navigational metadata. The relationships between data and between annotations and data are stored as first class objects in the system. They can be viewed as instances drawn from a small set of graph types. General purpose programs can be written which allow users explore these graphs and gain insights into their data. This process of data navigation, successive inclusion and filtering of objects, provides powerful paradigm for data exploration.

*This paper lays out the underlying core ideas, progress to date, and plans for near term work.*



## **O-38: MARCONI FUSION: The new high performance computing facility for European nuclear fusion modeling**

F.Iannone<sup>1</sup>, G.Bracco<sup>1</sup>, C.Cavazzoni<sup>2</sup>, R.Coelho<sup>3</sup>, D. Coster<sup>4</sup>, O. Hoenen<sup>4</sup>, A.Maslennikov<sup>2</sup>, S.Migliori<sup>1</sup>, M.Owsiak<sup>5</sup>, A.Quintiliani<sup>1</sup>, B.Palak<sup>5</sup>, F.Robin<sup>6</sup>, E.Rossi<sup>2</sup>, I.Voitsekhovitch<sup>7</sup>

<sup>1</sup> ENEA, via Lungotevere Thaon di Ravel 76, Rome 00196, Italy

<sup>2</sup> CINECA, via Magnanelli 6/3, Casalecchio di Reno, Bologna 40033, Italy

<sup>3</sup> Instituto de Plasmas e Fusão Nuclear, Av. Rovisco Pais 1, 1049-001 Lisboa, Portugal

<sup>4</sup> Max-Planck-Institut für Plasmaphysik, Boltzmannstraße 2, 85748 Garching bei München, Germany

<sup>5</sup> Poznan Supercomputing and Networking Center, 61-704 Poznan, Noskowskiego 10, Poland

<sup>6</sup> GENCI, 12 rue de l'Eglise 75015 Paris, France

<sup>7</sup> EUROfusion, Boltzmannstraße 2, 85748 Garching bei München, Germany

E-mail of Corresponding Authors: [francesco.iannone@enea.it](mailto:francesco.iannone@enea.it)

The new HPC facility for Fusion is in operation since July 2016 after the end of the Helios age. The supercomputer is hosted at CINECA and it is a fraction of the Tier-0 MARCONI HPC system. Thanks to a customized technical project done by ENEA, in a joint development agreement with CINECA, the European community of fusion modelling can exploit the last available CPU technologies, following the CINECA HPC roadmap towards 50 PFlops on 2018. The MARCONI Fusion fraction is being delivered in two phases: the first one is 1 PFlops of CPU multi-core architecture based on the Intel Broadwell, already in operation since July 2016, and the second one is 5 PFlops of the same architecture based on the INTEL Skylake will be deployed in July 2017. Furthermore the project has foreseen the usage of the second generation of Intel Phi many-core architecture based on Knights Landing.

Within this framework, ENEA/CINECA has provided the operation support of the Gateway infrastructure of EuroFusion Work-Package Code Development. A new Gateway HPC system is in operation at CINECA since Jan. 2017 thanks to the data migration and software porting activities carried out by ENEA/CINECA team and Code Platform Team of EuroFusion as well. The new Gateway infrastructure is embedded in the MARCONI Fusion fraction, sharing the same 100 Gbps low-latency network based on the Intel OmniPath technology.

The paper describes the technical details and the performances of MARCONI, one of the largest HPC OmniPath based infrastructure, and compares the multi-core versus many-core architectures for massive parallel applications.

## **O-39: Methodology for the implementation of real time image processing systems using FPGAs and GPUs and their integration in EPICS using nominal device support**

S.Esquembri<sup>1</sup>, J.Nieto<sup>1</sup>, M.Ruiz<sup>1</sup>, G.de Arcas<sup>1</sup>, A.Gracia<sup>1</sup>

<sup>1</sup> *Instrumentation and Applied Acoustic Research Group, Technical University of Madrid, Madrid, Spain*

E-mail of Corresponding Author: [Sergio Esquembri sesquembri@i2a2.upm.es](mailto:Sergio.Esquembri@i2a2.upm.es)

There is an increasing interest to improve the processing capabilities for imaging diagnostics in fusion devices [1][2]. Furthermore, the continuous upgrades of the hardware systems used in these tasks require a flexible platform that obtains the maximum performance of these technologies: cameras, frame-grabbers, and parallel processing architectures using FPGAs, GPUs, and multicore CPUs. This work presents the methodology for the development of real-time image processing applications using ITER CODAC CORE SYSTEM (CCS) software tools and the hardware configuration defined in the ITER fast controllers hardware catalog, by mean of Camera Link cameras [3], Camera Link FPGA-based frame-grabbers and NVIDIA GPUs. The integration with EPICS is provided using the Nominal Device Support approach and the IRIO tools integrated in CCS. This device support provides a precise control of the camera, a balancing of the parallel computing load between the FPGA and the GPU, and an efficient movement of the data between the different elements of the architecture. In order to validate the full development cycle an EPICS application has been developed implementing different algorithms frequently used such as: histogram, detection of levels, and classification of zones within an image, compression with or without losses. Results of the performance obtained are presented highlighting the different for various configurations running the selected algorithms.

### **References:**

- [1] MAKOWSKI, D., MIELCZAREK, A., PEREK, P., JABLONSKI, G., ORLIKOWSKI, M., NAPIERALSKI, A., MAKIJARVI, P., SIMROCK, S. and MARTIN, V., 2014. High - performance image acquisition and processing system with MTCA.4, Real Time Conference (RT), 2014 19th IEEE - NPSS 2014, pp. 1 - 2.
- [2] V. MARTIN, V. MONCADA, G. DUNAND, Y. CORRE, E. DELCHAMBRE, J.M. TRAVERE, 2011, Integrated software for imaging data analysis applied to edge plasma physic and operational safety, Fusion Engineering and Design, vol. 86, pp. 270-278, Jun 2011.
- [3] S. ESQUEMBRI, M. RUIZ, E. BARRERA, D. SANZ, A. BUSTOS, R. CASTRO, J. VEGA, Implementation of an image acquisition and processing system based on FlexRIO, CameraLink and areaDetector, Fusion Engineering and Design, vol. 112, pp. 937-941, Nov 2016

*This research has been partially supported by the Joint Research Project between the Institute of Plasma Physics of the CAS and the Institute of Electronics BAS BG and by MSMT project # LM2015045.*

## O-40: Status of ITER Remote Experimentation Centre

J. Farthing<sup>1</sup>, T. Ozeki<sup>2</sup>, S. L. Clement<sup>1</sup>, N. Nakajima<sup>3</sup>, F. Sartori<sup>1</sup>, G. De Tommasi<sup>10</sup>, G. Manduchi<sup>4</sup>, P. Barbato<sup>4</sup>, A. Rigoni<sup>4</sup>, V. Vitale<sup>5</sup>, G. Giruzzi<sup>6</sup>, M. Mattei<sup>1</sup>, A. Mele<sup>1</sup>, F. Imbeaux<sup>6</sup>, J. -F. Artaud<sup>6</sup>, F. Robin<sup>7</sup>, E. Joffrin<sup>8</sup>, A. Hynes<sup>8</sup>, O. Hemming<sup>8</sup>, M. Wheatley<sup>8</sup>, S. Ohira<sup>2</sup>, S. Ide<sup>2</sup>, Y. Ishii<sup>2</sup>, M. Matsukawa<sup>2</sup>, H. Kubo<sup>2</sup>, T. Totsuka<sup>2</sup>, H. Urano<sup>2</sup>, O. Naito<sup>2</sup>, N. Hayashi<sup>2</sup>, Y. Miyata<sup>2</sup>, M. Namekawa<sup>2</sup>, A. Wakasa<sup>2</sup>, T. Oshima<sup>2</sup>, H. Nakanishi<sup>3</sup>, K. Yamanaka<sup>9</sup>

<sup>1</sup>Fusion for Energy, Barcelona, Spain, <sup>2</sup>QST, Rokkasho, Japan, <sup>3</sup>National institute for Fusion Science, Rokkasho, Japan, <sup>4</sup>Consorzio RFX, Padua, Italy, <sup>5</sup>EUROfusion, ENEA, Italy, <sup>6</sup>EUROfusion, CEA, France, <sup>7</sup>CEA, Saclay, France, <sup>8</sup>EURATOM-CCFE Fusion Association, Culham Science Centre, UK, <sup>9</sup>National Institute of Informatics, Tokyo, Japan, <sup>10</sup>Univ. di Napoli Federico II, Napoli, Italy

The project of the ITER Remote Experimentation Centre (REC) (one of the three sub-projects of the International Fusion Energy Research Centre (IFERC)) is progressing under the agreement between the Government of Japan and the European Atomic Energy Community for the joint implementation of the Broader Approach (BA) activities in the field of fusion energy research. The objectives of the REC activity are to identify the functions and solve the technical issues for the construction of the REC for ITER at Rokkasho, and to develop the remote experiment system and verify the functions required for the remote experiment by using the Satellite Tokamak (JT-60SA) facilities in order to facilitate the future exploitation of the future experiments of ITER and JT-60SA [1, 2]. In the end, the functions of REC will be tested, and the total system is demonstrated by using JT-60SA and existing facilities in the EU, such as JET and WEST.

The hardware of the REC has been prepared in Rokkasho Japan, which has the remote experiment room with a large video wall to show the plasma and operation status, IT equipment and the storage system by the reuse of the supercomputer of Helios. The REC facility will be widely used for the remote collaboration. Also, the broadband network infrastructure of 10Gbps has been produced. Using this network system, the fast data transfer from ITER to REC has been examined in 2016, and the transfer of the full data in the initial ITER experiment has been demonstrated [3]. Secure remote experiment system has been developed, using JT-60SA, that has functions for preparing and setting of shot parameters, viewing the status of control data, streaming of the plasma status, data-exchange function of shot events, and monitoring of the facility operation. The software of the remote data analysis has been progressed significantly. The unified software infrastructure to access data stored both at on- and remote- sites and the documentation management system are also being developed. Numerical simulation for preparation and performance estimation of the shots by the appropriate implementation of the simulation code, such as the integrated simulation code, and the analysis codes for the plasma shots.

## References

- [1] OZEKI, T., S. L. Clement, N. Nakajima, Fusion Eng. Des. **89** 529-531 (2014)
- [2] OZEKI, T., S. L. Clement, N. Nakajima, Fusion Eng. Des. **112** 1055-1058 (2016)
- [3] YAMANAKA, K., NAKANISHI, T., et al., submitted for this meeting of 11<sup>th</sup> IAEA TM

## O-41: Assessing remote data access feasibility for the ITER Remote Experimentation Centre

A. Rigoni<sup>1</sup>, G. Manduchi<sup>1</sup>, G. De Tommasi<sup>2</sup>, N. Nakajima<sup>3,4</sup>, N. Nakanishi<sup>4</sup>, F. Sartori<sup>5</sup>, Y. Sugie<sup>3</sup>

<sup>1</sup>*Consorzio RFX, Corso Stati Uniti 4, Padova 35127, Italy*

<sup>2</sup>*Consorzio CREATE - Università degli Studi di Napoli Federico II, via Claudio 21, 80125, Napoli, Italy*

<sup>3</sup>*BA IFERC Project Team, Rokkasho-mura, Aomori 039-3212, Japan*

<sup>4</sup>*National Institute for Fusion Science, Toki, 509-5292, Japan*

<sup>5</sup>*Fusion for Energy, 08019 Barcelona, Spain*

E-mail of Corresponding Author: [gabriele.manduchi@igi.cnr.it](mailto:gabriele.manduchi@igi.cnr.it)

Remote data access is a mandatory requirement for large devices operated by international teams. Data acquired during experimental sessions should be soon available at remote sites for on-line analysis and visualization. Network throughput plays an important role, but overall performance depends also on the strategies adopted by the data system in order to optimize data transfer, increasing throughput and reducing latency.

The ITER Remote Experimentation Centre (REC) in Rokkasho [1] is one of the projects currently implemented within the Broader Approach agreement [2]. The ultimate objective of the REC is to allow researchers to take part in the experimentation on ITER from a remote location. The technologies developed for the REC include Remote Data Access (RDA) tools [3], which allow the users to access to the experimental data, regardless their geographical location.

MDSplus is the most widespread data system that is used in the fusion community for remote data access and is the candidate technology for exporting ITER data at the REC.

The paper reports the measured performance in remote data access between Europe and Japan using MDSplus and describes several strategies that have been adopted in order to optimize data transfer. In particular, solutions for data streaming requirements and remote access of very large signals, as they represent important requirements in large experiments.

### References:

[1] OZEKI, T., et al., Fus. Eng. Des. 112, 1055-1058 (2016)

[2] TSUNEMATSU, T., Fus. Eng. Des. 84 122-124 (2009)

[3] DE TOMMASI, G., et al., Fus. Eng. Des. 96-97, 769-771 (2015)

## O-42: On-demand file transfer for ITER remote experiments

K.Yamanaka<sup>1</sup>, H.Nakanishi<sup>2</sup>, T.Ozeki<sup>3</sup>, N.Nakajima<sup>2</sup>, S.Abe<sup>1</sup>, S.Urushidani<sup>1</sup>, T.Yamamoto<sup>2</sup>,  
And Y.Ishi<sup>3</sup>

<sup>1</sup> *National Institute of Informatics (NII), Chiyoda, Tokyo, Japan*

<sup>2</sup> *National Institute of Fusion Science (NIFS), Toki, Gifu, Japan*

<sup>3</sup> *National Institutes for Quantum and Radiological Science and Technology (QST), Rokkasho, Aomori, Japan*

E-mail of Corresponding Author: [yamanaka@nii.ac.jp](mailto:yamanaka@nii.ac.jp)

The ITER Remote Experimentation Centre (REC) [1] is constructing in Rokkasho, Japan, as a Broader Approach (BA) activity, for the remote participation (RP) to ITER experiments. REC aims to renovate the conventional RP techniques with a final goal to make local and remote sites equivalent regarding data accessibility.

In the initial phase, ITER will generate scientific data with 2 GB /s speed, the data amount is estimated 1TB per shot, and the plasma pulse interval is considered one-half hour or one hour long. We executed a data transfer test from ITER to REC, in which 1TB data was transferred 100 times at 8 Gbps target speed in 30-minute intervals by using the file transfer protocol MMCFTP [2]. We achieved 7.2Gbps average speed (19 min 42 sec average transmission time), and all transmission finished within 30 minute deadline. This result has demonstrated the feasibility to build a full replication site of ITER data even at a distant place [3]. However, an issue remains to accomplish the final goal of REC. In the test, we assume that data transmission to REC starts after a shot is over. Researchers at REC should wait for 20 minutes than ones at ITER to access ITER data. In this paper, we examine applying pipeline technique to data transfer between ITER and REC to minimize data access delay at remote site. If ITER data is outputted as files divided by adequate time slice (for example 10 sec), we can start transmission of the file of previous slice while data of next slice is being written to another file. In order to continuously transmission of files generated one after another, it is necessary to minimize the protocol overhead of the file transfer method. We investigate an extension of MMCFTP to support such type of file transfer. By using the extended MMCFTP, and under the international network between ITER and REC that have sufficient bandwidth (at least 20Gbps in ITER initial phase), researcher at REC can be access ITER data with delay of the time slice (i.e. 10 sec).

### References:

- [1] OZEKI, T., et al., "Progress on ITER remote experimentation centre," Fusion Eng. Des. 112, 2016.
- [2] YAMANAKA, K., et al., "A TCP/IP-based constant-bit-rate file transfer protocol and its extension to multipoint data delivery," Fusion Eng. Des., 89 (5), 2014.
- [3] NAKANISHI, H., et al., "High Performance Data Transfer for Full Data Replication between ITER and the Remote Experimentation Centre, " 26th IAEA Fusion Energy Conference, October, 2016.

### O-43: Remote operation of EAST

D.P. Schisel<sup>1</sup>, E. Coviello<sup>1</sup>, N. Eidielis<sup>1</sup>, S. Flanagan<sup>1</sup>, F. Garcia<sup>1</sup>, D. Humphreys<sup>1</sup>, M. Kostuk<sup>1</sup>, M. Lanctot<sup>1</sup>, M. Margo<sup>1</sup>, D. Miller<sup>1</sup>, C. Parker<sup>1</sup>, B. Penaflo<sup>1</sup>, J.P. Qian<sup>2</sup>, X. Sun<sup>2</sup>, H. Tan<sup>2</sup>, M. Walker<sup>1</sup>, B. Xiao<sup>2</sup>, and Q. Yuan<sup>2</sup>

<sup>1</sup>*General Atomics, PO Box 85608, San Diego, California 92186-5608 USA*

<sup>2</sup>*Institute of Plasma Physics, Chinese Academy of Sciences, Hefei, China*

E-mail of Corresponding Author: [Schissel@fusion.gat.com](mailto:Schissel@fusion.gat.com)

General Atomics' (GA) scientists in the United States remotely conducted experimental operation of the Experimental Advanced Superconducting Tokamak (EAST) in China during its third shift. Scientists led these experiments in a dedicated remote control room that utilized a novel computer science hardware and software infrastructure to allow data movement, visualization, and communication on the time scale of EAST's shot cycle. This Fusion Science Collaboration Zone and the remote control room were used to conduct remote experiments on EAST on vertical controllability by triggering vertical displacement events to assess vertical growth rate and nonlinear evolution while a team at EAST provided scientific assistance and engineering operations oversight. The level of capability deployed to remotely operate EAST required the creation of an infrastructure that was a major advancement over what had previously been achieved in the fusion community. One component of the Fusion Science Collaboration Zone is data movement, where large amounts of data can be moved between continents in a short time between shots and real-time data from control systems can be moved almost instantaneously. The large datasets are moved with an updated computer networking technique that yields a data transfer rate utilizing up to 85% of the 1 Gb/s network connection between EAST and GA, a 300-fold increase in data transfer rate over that available using the traditional transmission protocol. Combining this speed with an event system tied to the EAST shot cycle allows automatic initiation of data transfers, enabling bulk EAST data to be transferred to GA within minutes. After the bulk data arrives at GA, it is served via MDSplus allowing approved US clients to securely and rapidly access EAST data. The real-time data transfer is accomplished by reading data directly from the EAST Plasma Control System memory through a networked, in-memory data structure server that receives the data at GA to make it available to the scientific team. This architecture avoids multiple clients within the U.S. requesting data from EAST and competing for the long-haul network's bandwidth that is considerably slower than the network within the U.S.

*This work was supported by General Atomics internal research and development funds.*

## O-44: NSTX-U Advances in real-time deterministic PCIe-based internode communication

K. G. Erickson and M. D. Boyer

*Princeton University Plasma Physics Lab, Princeton, NJ 08540, USA*

E-mail of Corresponding Author: [kerickso@pppl.gov](mailto:kerickso@pppl.gov)

Distributing control mechanisms across modern commercial off the shelf (COTS) GNU/Linux systems often introduces difficult to mitigate non-deterministic nature. Existing methods to address this problem involve non-real-time technologies such as RDMA over Infiniband or custom Ethernet solutions that trade determinism for ease of use or lower cost. The National Spherical Torus Experiment Upgrade (NSTX-U) [1] is pursuing a new design that allows direct communication between heterogeneous systems with less than one microsecond of latency and less than one microsecond of jitter on that latency, outside of the constant transmission delay at the physical layer. The future design of the NSTX-U Real-time Communication System will utilize direct PCIe-to-PCIe communication with kernel support tuned for low overhead, allowing two (or more through a switch) RT systems to communicate and share resources as one larger entity. This greatly increases the processing capability of the primary PCS, turning previously insurmountable computational challenges into a more manageable divide and conquer parallel task.

Historically, the system designs in use on NSTX-U have refrained from distributed computing to avoid the overhead of moving data between nodes, instead opting for an ever increasing core count within a single node. The current Plasma Control System (PCS) systems use 64 AMD Opteron 6386 SE cores in a single host, which is enough to meet all current needs [2]. Future computational demands, however, are exceeding the growth curve of the processing that can fit into a single computer. Outside of special proprietary motherboard designs that allow for eight CPU sockets, there is no practical COTS hardware vendor supporting more than four CPUs for a single system installation. The new real-time communication design will instead enable coupling multiple 64-core nodes into a larger overall system of computers that can grow over time like existing switched fabric solutions, but with the determinism present in the one-monolithic-system approach.

### References:

- [1] MENARD, J., *et al.*, <https://doi.org/10.1088/0029-5515/52/8/083015>
- [2] ERICKSON, K. G., *et al.*, <http://dx.doi.org/10.1016/j.fusengdes.2014.04.069>

## **O-45: Inter-application communication during LHD consecutive short pulse discharge experiment**

M.Emoto<sup>1</sup>, H.Nakanishi<sup>1</sup>, M.Yoshida<sup>1</sup>, M.Ohsuna<sup>1</sup>, H.Ogawa<sup>1</sup>, S.Imazu<sup>1</sup>, H.Maeno<sup>1</sup>, T.Ito<sup>1</sup>,  
M.Yokota<sup>1</sup>, M.Nonomura<sup>1</sup>, and M.Aoyagai<sup>1</sup>

<sup>1</sup>*National Institute for Fusion Science, 322-6 Oroshi, Toki 509-5292, Japan*

LHD short pulse experiments are executed every three minutes. After the end of the discharge, the scientists must collect, analyse, visualize the last acquired data of the discharge, and prepare for the next discharge. From the beginning, the computer environment of the LHD experiment has been built as a network distributed system, and various computers have been used for data acquisition or physical analysis. When one program is finished on one computer, it must send the results to the other computers to run programs. In order to finish all the task before the next discharge, smooth communication is required. To exchange the information among the applications running on the different computers, the authors have tried various methods [1-3], such as a commercial software to share the memory over the network, simple network file sharing method, IP multicast, web interfaces, and so on. The purpose of this presentation is to share our experiences of try and error to build the network distributed systems for the consecutive plasma discharge experiments.

### **References:**

- [1] NAKANISHI, H. *et al.*, Fusion Sci. Technol. **58**, pp.445-457 (2010)
- [2] NAGAYAMA, Y.*et al.*, Fus. Eng. Des. **83**, pp170-175 (2008)
- [3] EMOTO, M., *et al.*, Fus. Eng. Des. **112**, pp814-817 (2008)



## O-46: Development real-time data archive system for KSTAR real-time network

Giil Kwon<sup>1</sup>, Woongryol Lee<sup>1</sup>, Taegu Lee<sup>1</sup> and Jaesic Hong<sup>1</sup>

*Control Team, National Fusion Research Institute, Daejeon, South Korea*

E-mail of Corresponding Author: [giilkwon@nfri.re.kr](mailto:giilkwon@nfri.re.kr)

This paper presents the KSTAR (Korea Superconducting Tokamak Advanced Research) real-time data archiving system for real-time network. In most fusion experiments, stable and low latency real-time network is essential to achieve real-time controllability. For stable operation of real-time network, inspection and supervision of the network is essential. By archiving the network data, it is possible to analyse the performance and status of network. In the KSTAR, for stable operation of real-time network, the real-time network data archiving system has been developed to monitor and archive real-time network data that is used to control plasma and to send diagnostic data to PCS in real-time. The KSTAR adopts reflective memory (RFM) and synchronous data bus network (SDN) as a real-time network and archive these real-time data. SDN is an ITER real-time network based on a UDP multicast over a 10-GbE cut-through packet-switching infrastructure. This paper presents the algorithm of the real-time data archiving system and experimental result of this system. The real-time data archiving system operate in two phases. During the experiment, the archiving system store data from these real-time networks in real-time. After finishing the experiment the system send this archived data to MDSplus[2] data server. This system stores each data in accordance to the KSTAR timing system. Therefore, each data synchronizes with the KSTAR timing system. To configure this system, EPICS (Experimental Physics and Industrial Control System) [3] and AsynDriver [4] was used. To operate this system in real-time, the system was implemented on MRG-R kernel 3.10 and uses the MCoreUtil[5]. The system was tested to validate the performance of this archiving system. The test results show the real-time performance of this system.

### References:

- [1] STILLERMAN, J. A., et al. MDSplus data acquisition system. *Review of Scientific Instruments*, 1997, 68.1: 939-942.
- [2] DALESIO, Leo; KRAIMER, M. R.; KOZUBAL, A. J. EPICS architecture. In: *ICALEPCS*. 1991. p. 92-15.
- [3] KRAIMER, Martin; RIVERS, Mark; NORUM, Eric. EPICS: Asynchronous driver support. In: *ICALEPCS*. 2009. p. 074-5.
- [4] LANGE, Ralph; II, BESSY. Optimizing EPICS for multi-core architectures.

## List of Posters:

### Poster Session 1

**P1/1/01:** Chen Y., *Design of Real-Time Data Acquisition System for POLarimeter-INTerferometer diagnostic*

**P1/1/02:** Fuchs J.C., *CLISTE equilibrium reconstruction in ASDEX Upgrade using toroidally distributed magnetic measurements and possible implications on the plasma position control*

**P1/1/03:** Gerkšič S., *SVD-based fast online MPC for ITER plasma current and shape control*

**P1/1/04:** Guo Y., *Preliminary results of a new MIMO plasma shape controller for EAST*

**P1/1/05:** Huang Y., *Improvement of GPU parallel real-time equilibrium reconstruction for plasma control*

**P1/1/06:** Li C.C., *Preliminary Implementation of the Real-time Data Sharing System Based on RFM for EAST*

**P1/1/07:** Manduchi G., *A Portable Control And Data Acquisition Solution*

**P1/1/08:** Shah M., *FPGA based Trigger and Timing System for Aditya-U Tokamak Operation and Control*

**P1/1/09:** Shin G.W., *Automatic Detection of L-H Transition in KSTAR by Support Vector Machine*

**P1/1/10:** Signoret J., *Coupling Plasma Control System and Pulse Schedule Editor for WEST Operation*

**P1/1/11:** Stepanov D., *ITER CODAC Operation Request Gatekeeper: First Implementation*

**P1/1/12:** Davis W. on behalf of Varshney S., *Design maturity of Plant Instrumentation and Control for ITER XRCS-Survey*

**P1/1/13:** Vega J., *Real-time implementation with FPGA-based DAQ system of a probabilistic disruption predictor from scratch*

**P1/1/14:** Wang Y., *Closed-loop control-oriented system identification for EAST plasma shape response model*

**P1/1/15:** Wu K., *Radiative Feedback for Divertor Heat Spread on EAST*

**P1/1/16:** Xiao B.J., *Model-based plasma vertical stabilization and position control at EAST*

**P1/1/17:** Yeole Y.G., *An Automation of Vacuum System for SMARTEX-C*

**P1/1/18:** Yuan Q.P., *Upgrade of EAST plasma control system for steady-state advanced operation*

**P1/1/19:** Zhang Z.C., *Progress in the development of EAST timing synchronization system upgrade based on precision time protocol*

**P1/1/20:** Lee W. on behalf of Hahn S.-H., *Achievements and lessons learned from first operation of KSTAR plasma control system upgrade*

**P1/2/01:** Astrain M., *Implementation of the Fast Plant Interlock System for the ITER Poloidal Field and Central Solenoid Coil's Power Convertor protection*

**P1/2/02:** Schacht J., *The gas supply and gas inlet control systems of the fusion experiment Wendelstein 7-X*

**P1/2/03:** Ruiz M. on behalf of Barrera E., *Methodology for the Deployment of ITER Fast Plant Interlock System*

## Poster Session 2

**P2/3/01:** Batista A., *Tests results of chopper based integrator prototypes for the ITER magnetics*

**P2/3/02:** Behler K.C., *Refurbishment, consolidation, and real-time enabling of plasma diagnostics using the ASDEX Upgrade SIO/Pipe data acquisition concept*

**P2/3/03:** Carvalho B.B., *Design, Implementation and Commissioning of ATCA based high-speed multichannel Data Acquisition Systems for Magnetic Diagnostics in W7-X*

**P2/3/04:** Correia M., *PCIe Hot-Plug for high-availability ATCA fast controller platform*

**P2/3/05:** Lee T., *EPICS data acquisition system for plasma electron density measurement based on FPGA on KSTAR*

**P2/3/06:** Li Y., *A new implementation of data process in JRTF*

**P2/3/07:** Martinov S., *Recent developments in video data acquisition, distribution and analysis at ASDEX Upgrade*

**P2/3/08:** Pereira R.C., *Neutron/Gamma discrimination code based on trapezoidal filter*

**P2/3/09:** Pires de Sá W., *MDSplus, FPGA, Control and Data Acquisition System at TCABR Tokamak: Small Fusion Devices Contributing with the Big Experiments*

**P2/3/10:** Rodrigues A.P., *Taking advantage of the intercommunication features of IPMCs in ATCA CDAQ systems*

**P2/3/11:** Ruiz M., *Methodology for the implementation with OpenCL of high performance computing FPGA-based applications using AreaDetector's plugins and EPICS*

**P2/3/12:** Santos B., *Control and Data Acquisition Software Upgrade for JET Gamma-Ray Diagnostics*

**P2/3/13:** Wang Y., *A Fiber-optic analog Isolator of up to 10 MHz bandwidth*

**P2/3/14:** Zwang H., *Current status of EAST data acquisition system*

**P2/4/01:** Krom J. G., *Compression of Time-Vectors in W7-X Archived Measurements*

**P2/4/01a:** Krom J. G., *Blue/Green Deployment of W7-X Archive Servers*

**P2/4/02:** Li S., *A Method for Similar Waveform Search on EAST Data*

**P2/4/03:** Liu Q., *The Data Accessing and Processing Stack of J-TEXT Database Cloud*

**P2/4/04:** Migliori S., *Files synching and sharing tools for Pellet Injector data handling*

**P2/4/05:** Qian J., *Data management on technical data of EAST magnets*

**P2/4/06:** Shiraiwa S., *Tools to export machine-readable datasets from IDL,  $\pi$ Scope and MATLAB*

**P2/5/01:** Fabregas E., *Software parallelization of a probabilistic classifier based on Venn prediction: application to the TJ-II Thomson Scattering*

**P2/5/02:** Farias G., *Applying deep learning for improving image classification in fusion*

**P2/5/03:** Farias G., *Image Classification by using a reduced set of features in the TJ-II Thomson Scattering Diagnostic*

**P2/5/04:** Fernandes A., *New FPGA processing code for JET gamma-ray camera upgrade*

**P2/5/05:** Zhang R.R., *A visualization tool for EAST diagnostic profiles data*

**P2/5/06:** Rattá G.A., *An adaptive disruption predictor for avoidance/mitigation purposes*

**P2/6/01:** Chai W.T., *Web-based discharge scenario query system on EAST*

**P2/6/02:** Dormido-Canto S., *Distributed collaborative environment for software applications*

**P2/6/03:** Li D., *Preliminary Realization of Immersive EAST System Using Virtual Reality*

**P2/6/04:** Xia J.Y., *Improvement of Virtual EAST System based on WebVR*

**P2/7/01:** Liu G., *ITER CODAC Network Design*

## **P1/1/01: Design of real-time data acquisition system for POLarimeter-INTerferometer diagnostic**

Y. Chen<sup>1</sup>, S. Li<sup>1</sup>, Z.P. Luo<sup>1</sup>, Q.P. Yuan<sup>1</sup>, Y. Huang<sup>1</sup>, B.J. Xiao<sup>1</sup>

*Institute of Plasma Physics, Chinese Academy of Sciences, Hefei, 230031, China*

E-mail of Corresponding Author: [cheny@ipp.ac.cn](mailto:cheny@ipp.ac.cn)

The real-time data acquisition system is designed for providing POLarimeter- INTerferometer (POINT) diagnostic [1] data to P-EFIT in real-time. The digital phase detector of POINT can provide real-time Faraday rotation angle and density phase shift output which can be used in plasma control [1]. P-EFIT, a code based on Graphic Processing Units (GPU) parallel computation and EFIT frame-work [2], is developed for EAST plasma control. Now P-EFIT includes a new algorithm for real-time plasma current profile reconstruction with POINT diagnostic data. The new real-time data acquisition system has been designed based on reflective memory (RFM) network and LabVIEW real-time operation system. It can be divided into three modules: data acquisition, data pre-process and data real-time transmission. The data acquisition module gets shot message from the data acquisition console following the rules of EAST data acquisition system and acquires the POINT diagnostic data after signal conditioning. The data pre-process module can processes the data for the aim of reducing noise and cutting down the workload of P-EFIT. EAST Plasma Control System (PCS) has established a RFM network and P-EFIT gets all data just from the RFM network. So the data transmission module chooses RFM network to transfer processed data in real-time, and then P-EFIT can performs a new equilibrium reconstruction iteration with the most recent data from the data transmission module and last equilibrium result. The data transmission frequency is 20 kHz which satisfy the requirements of P-EFIT real-time plasma current profile reconstruction. The details will be shown in the paper.

### **References:**

- [1] LIU, H. Q., et al., REVIEW OF SCIENTIFIC INSTRUMENTS **85**, 11D405 (2014)
- [2] HUANG, Y., et al., Fusion Engineering & Design **112**, 1019-1024(2016)

## **P1/1/02: CLISTE equilibrium reconstruction in ASDEX Upgrade using toroidally distributed magnetic measurements and possible implications on the plasma position control**

J.C. Fuchs<sup>1</sup>, R. Fischer<sup>1</sup>, L. Giannone<sup>1</sup>, P.J. Mc Carthy<sup>2</sup>, E. Strumberger<sup>1</sup>, W. Suttrop<sup>1</sup>,  
M. Willensdorfer<sup>1</sup>, and the ASDEX Upgrade Team<sup>1</sup>

<sup>1</sup>*Max-Planck-Institute for Plasma Physics, Boltzmannstr 2, 85748 Garching, Germany*

<sup>2</sup>*Department of Physics, University College Cork, Cork, Ireland.*

E-mail of Corresponding Author: [svoboda@jfifi.cvut.cz](mailto:svoboda@jfifi.cvut.cz), [stockel@ipp.cas.cz](mailto:stockel@ipp.cas.cz), [adamek@ipp.cas.cz](mailto:adamek@ipp.cas.cz),  
[dimitrova@ipp.cas.cz](mailto:dimitrova@ipp.cas.cz)

The main tool for the equilibrium reconstruction at ASDEX Upgrade is the CLISTE interpretative code [1] which numerically solves the Grad-Shafranov equation as a best fit to a set of experimental measurements, especially from magnetic probes and flux loops. The same algorithm is also applied to generate a database of precalculated equilibria, which is used for the real time plasma position control.

Since the Grad-Shafranov equation assumes toroidal symmetry of the plasma, any nonaxisymmetric effects on the equilibrium are not taken into account; especially magnetic perturbations by the saddle coils can produce a significant deformation of flux surfaces [2]. However, CLISTE uses toroidally averaging flux loops, and up to now magnetic probes for the poloidal component of the magnetic field ( $B_\theta$ -probes) restricted to one toroidal location. The resulting equilibrium therefore represents a toroidal average, strongly weighted by the tangential poloidal field at the toroidal location of these  $B_\theta$ -probes.

Recently, a second set of  $B_\theta$ -probes has been brought into operation, which is displaced toroidally by  $45^\circ$  with respect to the first set. First reconstructions of the equilibrium using either of these sets of  $B_\theta$ -probes during a shot with magnetic perturbations show differences in the plasma surface at the toroidal positions of these probes which are in accordance with calculations from magnetic field line tracing codes or 3D equilibrium reconstruction with the NEMEC code.

For the next campaign further sets of  $B_\theta$ -probes at 4 further different toroidal positions have been installed. This will allow either to compare equilibria at different toroidal positions more detailed (using  $B_\theta$ -probes at one of these toroidal positions only), or to reconstruct equilibria which are toroidally more uniformly averaged (using  $B_\theta$ -measurements from different toroidal positions simultaneously). Such reconstructed equilibria will be investigated, and possible implications on the generation of the database for the real time plasma position control will be discussed.

### **References:**

- [1] MC CARTHY, P.J., et al., Plasma Phys. Control. Fusion 54 015010 (2012).
- [2] WILLENSDORDER, M., et al., IAEA conference EX/P6-25 (2016).

## **P1/1/03: SVD-based fast online MPC for ITER plasma current and shape control**

Samo Gerkšič<sup>1</sup>, Boštjan Pregelj<sup>1</sup>, Matija Perne<sup>1</sup>, Marco Ariola<sup>2</sup>, Gianmaria De Tommasi<sup>3</sup> and Alfredo Pironti<sup>3</sup>

<sup>1</sup>*Jozef Stefan Institute, Jamova cesta 39, 1000 Ljubljana, Slovenia*

<sup>2</sup>*Consorzio CREATE / Università di Napoli Parthenope, Dipartimento di Ingegneria, Centro Direzionale di Napoli, isola C4, 80143 Napoli, Italy*

<sup>3</sup>*Consorzio CREATE / Università di Napoli Federico II, Dipartimento di Ingegneria Elettrica e delle Tecnologie dell'informazione, Via Claudio 21, 80125 Napoli, Italy*

E-mail of Corresponding Author: [samo.gerksic@ijs.si](mailto:samo.gerksic@ijs.si)

In a magnetically confined tokamak reactor, the Plasma Current and Shape Controller (PCSC) is in charge of driving the voltages applied to the poloidal field coils, in order to control plasma shape, current, and position. In most cases, such as the ITER tokamak, the PCSC is designed taking into account the presence of the Vertical Stabilisation controller. The challenge of PCSC is to maintain the prescribed plasma shape and distance from the plasma facing components, in presence of disturbances, such as H-L transitions or ELMs, during the various phases of the discharge. Model Predictive Control (MPC) has gained wide industrial acceptance by facilitating a systematic approach to control of large-scale multivariable systems, with efficient handling of constraints on process variables and enabling plant optimization. With MPC, on-line optimization problems are being solved repeatedly at each sample time of the PCSC control loop for determining control actions. The computation time used to be the main obstacle for applying MPC to complex multivariable control problems with fast dynamics. However, our preliminary work [1] has already shown that MPC control is computationally feasible for a prototype implementation of ITER PCSC. This is obtained by solving the quadratic programming optimization problems using an adapted dual fast gradient method solver [2] and complexity-reduction techniques. In this work we present an MPC PCSC for the flat-top phase of ITER Scenario 1, which is able to control a large number of geometrical plasma shape descriptors using output-space reduction based on singular-value decomposition (SVD). A similar SVD-based approach was previously applied in the reference control scheme of CREATE [3], which is based on multivariable PI control. Performance evaluation in simulation generally shows better performance in terms of transient peak, settling time and the steady-state offset of gaps, and a much better performance in tracking of the plasma current than the reference scheme with most disturbances. Moreover, the proposed MPC PCSC is capable of avoiding superconductive current saturations, which is not the case with the reference scheme, and in some cases shows better performance regarding voltage saturations.

### **References:**

- [1] GERKŠIČ, S., et al., " Plasma current and shape control for ITER using fast online MPC", 20th IEEE Real Time Conference, Padova (2016).
- [2] GISELSSON, P., Improving Fast Dual Ascent for MPC - Part II: The Embedded Case, arXiv (2014).
- [3] AMBROSINO, G., et al., IEEE Trans. Plasma Science, 37(7) 1324-1331 (2009).

*This work has been carried out within the framework of the EUROfusion Consortium and has received funding from the Euratom research and training programme 2014-2018 under grant agreement No 633053. The views and opinions expressed herein do not necessarily reflect those of the European Commission.*



## P1/1/04: Preliminary results of a new MIMO plasma shape controller for EAST

Y. Guo <sup>a</sup>, B. J. Xiao <sup>a,b</sup>, Y.H. Wang <sup>c</sup>, L. Liu <sup>a</sup>, Y. Huang <sup>a</sup>, Q. P. Yuan <sup>a</sup>, A. Pironti <sup>d</sup>, R. Albanese <sup>d</sup>, R. Ambrosino <sup>d</sup>, F. Yang <sup>e</sup>, Q. L. Qiu <sup>a</sup>, G. Calabrò <sup>f</sup>, F. Crisanti <sup>f</sup>

<sup>a</sup> *Institute of Plasma Physics, Chinese Academy of Science, Hefei, 230031, China*

<sup>b</sup> *School of Nuclear Science and Technology, University of Science and Technology of China, Hefei, 230026, China*

<sup>c</sup> *CAS Key Laboratory of Basic Plasma Physics and Department of Modern Physics, University of Science and Technology of China, Hefei 230026, China*

<sup>d</sup> *CREATE - Università degli Studi di Napoli Federico II and Università di Napoli Parthenope - Via Claudio 21, 80125 Napoli*

<sup>e</sup> *Department of Computer Science, Anhui Medical University, Hefei, China*

<sup>f</sup> *ENEA Unità Tecnica Fusione, C.R. Frascati, Via E. Fermi 45, 00044 Frascati, Roma, Italy*

E-mail of Corresponding Author: [yguo@ipp.ac.cn](mailto:yguo@ipp.ac.cn)

The efficient and safe operation of large fusion devices relies on plasma configuration inside the vacuum chamber. Experimental Advanced Superconducting Tokamak (EAST) is a D-shaped cross section tokamak with 12 independent poloidal field (PF) coils (PF7 and PF9, PF8 and PF10 are connected together respectively). Due to EAST PF coils distribution, simply SISO control method seems weak for the control of complex plasma shape, such as snowflake configuration and X-divertor configuration. The MIMO control method <sup>[1]</sup>, which is numerical decoupling the relationship between plasma control parameters and PF coils, has the potential to cope with this problem. In this paper, we present a MIMO decoupling controller which has been implemented on the EAST. Tokamak Simulation Code (TSC) <sup>[2]</sup> is a numerical model of the axisymmetric tokamak plasma and the associated control systems, which has been benchmarked by EAST experimental data <sup>[3]</sup>. This MIMO controller has been validated by means of TSC simulation. In EAST control experiment for lower singular null (LSN) configuration (# 68988), the plasma shape is moved to the target shape by control the poloidal flux at several selected control points and Br & Bz at target X point. The results have shown that this method could be used for LSN shape control in EAST. It has the potential for EAST plasma shape control.

### References:

- [1] MARCO, A., PIRONTI, A., IEEE Control Syst. 25 65–75 (2005)
- [2] JARDIN S C, Pomphrey N and Delucia J, J. Comput. Phys. 66 481 (1986)
- [3] GUO, Y., et al., Plasma Phys. Control. Fusion 54 085022 (2012)

## **P1/1/05: Improvement of GPU parallel real-time equilibrium reconstruction for plasma control**

Y. Huang<sup>1</sup>, B.J. Xiao<sup>1,2</sup>, Z.P. Luo<sup>1</sup>, Q.P. Yuan<sup>1</sup>, Y. Guo<sup>1</sup>

<sup>1</sup>*Institute of Plasma Physics, Chinese Academy of Sciences, Hefei, China*

<sup>2</sup>*School of Nuclear Science & Technology, University of Science & Technology of China*

E-mail of Corresponding Author: [yaohuang@ipp.ac.cn](mailto:yaohuang@ipp.ac.cn)

P-EFIT, a GPU parallel equilibrium reconstruction code, is based on the EFIT framework [2], but takes advantage of massively parallel Graphical Processing Unit(GPU) cores to significantly accelerate the computation, and it has been preliminarily applied in plasma shape control[3].

Framework and algorithms in P-EFIT are redesigned to improve universality and flexibility. Updated parallel strategy and algorithms can be adjusted based on variable computational requirements automatically. These extend P-EFIT's ability to have flexible polynomial plasma current representation which is alterable during the discharge and to include internal diagnostics. With the development of GPU hardware, optimization is carried out for Tesla K20, K40 and Pascal TITAN X GPU. Robust parallel strategy and algorithms allow P-EFIT to achieve good computational performance regardless of different current representations, diagnostics and hardware environments. Compared with former P-EFIT version with 65×65 spatial grid on Tesla K20 [3], P-EFIT can complete one iteration in similar time about 300us with 129×129 spatial grid on Pascal TITAN X now.

P-EFIT provides a routine real-time plasma equilibrium reconstruction method which has high spatial resolution, customized modules and internal current profile calculation for plasma control in EAST. P-EFIT supports snowflake configuration, MIMO plasma shape control experiments in EAST and includes POINT diagnostic for real-time plasma current profile reconstruction. With all these improvements, P-EFIT can provide precise, detailed real-time equilibrium reconstruction for sophisticated plasma control in EAST.

### **References:**

- [1] YUE, X. N., et al. "Fast equilibrium reconstruction for tokamak discharge control based on GPU." *Plasma Physics and Controlled Fusion* 55.8 (2013): 085016.
- [2] LAO, L. L., et al. "MHD equilibrium reconstruction in the DIII-D tokamak." *Fusion science and technology* 48.2 (2005): 968-977.
- [3] HUANG, Y., et al. "Implementation of GPU parallel equilibrium reconstruction for plasma control in EAST." *Fusion Engineering & Design* 112(2016):1019-1024.

## **P1/1/06: Preliminary implementation of the real-time data sharing system based on RFM for EAST**

C.C. Li<sup>1,2</sup>, Z.S. Ji<sup>1</sup>, F. Wang<sup>1</sup>, Q. P. Yuan<sup>1</sup>, and S. Li<sup>1</sup>

<sup>1</sup> *Institute of Plasma Physics, Chinese Academy of Sciences, Hefei 230031, China*

<sup>2</sup> *University of Science and Technology of China, Hefei 230026, China*

E-mail of Corresponding Author: [licc@ipp.ac.cn](mailto:licc@ipp.ac.cn)

In the EAST experiments, plasma control system (PCS) needs a lot of diagnostic data produced by EAST distributed subsystems to meet the requirements of steady-state plasma control. But due to the factors of different sampling frequencies of subsystems and the signal distortion caused by long distance transmission, it's difficult for PCS to acquire all the diagnostic data by itself in each control cycle. So the real-time data sharing system is designed to solve the problem of real-time data transmission between PCS and subsystems so as to realize data sharing among EAST distributed systems.

In consider of transfer speed and required data amount, a “multiple network” structure composed of RFM network and Gigabit Ethernet network is applied in this system; in the meanwhile, MRG-realtime (Messaging, RealTime, and Grid) OS is adopted , which can provide deterministic response time. This system is responsible for transferring the diagnostic data collected by the data acquisition (DAQ) systems of subsystems to PCS through reflective memory (RFM) network in per control cycle and to the data server plugged to the Ethernet network in every time slice. All the relevant diagnostic data are to be available for PCS through the data sharing system and even PCS can choose some specified data according to its own needs during the plasma control. Likely, the above advantage for PCS also works for any EAST subsystems connected to the RFM network. In this paper, the details of the real-time data sharing system are described and the future work is also discussed.

## **P1/1/07: A portable control and data acquisition solution**

G. Manduchi<sup>1</sup>, A.Luchetta<sup>1</sup>, C. Taliercio<sup>1</sup>, A. Rigoni, F.Sartori<sup>2</sup>, A. Neto<sup>2</sup> and G. Carannante<sup>2</sup>

<sup>1</sup> *Consorzio RFX (CNR, ENEA, INFN, Università di Padova, Acciaierie Venete SpA), Padova, Italy*

<sup>2</sup> *Fusion For Energy, c/ Josep Pla, n° 2, Torres Diagonal Litoral, Edificio B3, 08019 Barcelona, Spain*

E-mail of Corresponding Author: [gabriele.manduchi@igi.cnr.it](mailto:gabriele.manduchi@igi.cnr.it)

Quasi continuous fusion experiments introduced a new paradigm in data acquisition systems, moving from strictly pulse-oriented data acquisition towards a configuration in which a continuous stream of data is managed by the system, able to provide data access during the discharge itself. Moreover, a modern Control and Data Acquisition System (CODAS) must provide an integrated vision of supervision, data acquisition and real-time control and a data centric view to the system combining raw, elaborated and configuration data.

The above requirements have been addressed by the CODAS system of the SPIDER experiment in the ITER Neutral Beam Test facility. The solution adopted in SPIDER CODAS integrates, by means of few interface components, three frameworks used in nuclear fusion and accelerator communities. The experience gained in the development of SPIDER CODAS highlighted the validity of the chosen approach, proving that the integration of existing and widely used frameworks represents a better choice in respect of the development from scratch of major system components.

A further refinement has recently started, aiming at providing a solution that is complete and generic, and, as such, easily portable to new applications, ranging from small systems to future fusion experiments. This has been achieved by providing further configurability not only to the used framework (fully configurable per se), but also to the connecting components, originally targeted at SPIDER CODAC.

The refined system described in the paper will be deployed in the ECT-FALCON Test Facility, used to test the ITER EC launcher components and the European Gyrotron prototype. Its implementation in other test facilities is foreseen, in order to provide a fast track to the development of complete and integrated control and data acquisition.

## **P1/1/08: FPGA based trigger and timing system for Aditya-U tokamak operation and control**

Minsha Shah, Praveenlal Edappala, Vismay Raulji, Rachna Rajpal, Joydeep Ghosh

*Institute for Plasma Research, Nr. Indira Bridge, Bhat, Gandhinagar-382428, India*

E-mail of Corresponding Author: [Minsha@ipr.res.in](mailto:Minsha@ipr.res.in)

Aditya tokamak is operated using transformer-converter based Pulse power system (APPS) which drives the different OT, TF and PF of the machine. The start of typical plasma shot operation begins with -2.4S trigger generated from the APPS system. Consequently two more triggers one at -40mS and one at -4mS will be generated. All these three triggers are taken with reference to loop voltage trigger. APPS system is about 70 mtrs apart from Aditya hall. Previously these triggers were transmitted from APPS unit to Aditya hall using copper cables, which are susceptible to noise pickups and falls triggering. In Aditya upgrade, we have developed Optical fiber based trigger transmitters & receivers. Also different subsystems of Aditya machine like gas-feed system, Data Acquisition systems, vacuum system, fast feedback firing circuits, ICRH, ECRH etc. require one of these triggers with programmable delay.

To cater this requirement Xilinx's make XC3S500E FPGA based hardware with many programmable features is developed. In FPGA 32 bit microblaze soft core processor is deployed. The trigger input selection & time delay for various systems can be set remotely through Graphical user interface developed in Labview. The FPGA based hardware is connected with PC through RS232 interface. Here UART soft IP of microblaze is configured for serial interface & 32 bit wide IO port is configured for address decoding & data latching. The hardware & software are configured for triggering 16 subsystems with any of three input triggers and time delay from 100uSec to 4Sec. The system is successfully tested and installed in Aditya-upgrade machine. Detailed design features will be described in this paper.

## **P1/1/09: Automatic detection of L-H Transition in KSTAR by support vector machine**

G.W. Shin<sup>1</sup>, J.-W. Juhn<sup>2</sup>, G.I. Kwon<sup>2</sup>, S.H. Son<sup>2</sup>, and S.H. Hahn<sup>2</sup>

<sup>1</sup> *Korea University of Science and Technology, 217 Gajeong-ro Yuseong-gu, 34113, Republic of Korea*

<sup>2</sup> *National Fusion Research Institute, 169-148 Gwahak-ro Yuseong-gu, 34133, Republic of Korea*

E-mail of Corresponding Author: [gwshin@nfri.re.kr](mailto:gwshin@nfri.re.kr)

In many tokamaks, a high confinement mode (H-mode) operation is general and essential. An H-mode plasma has higher density pedestal on the plasma edge hence it shows better performances than L-mode plasma from a view of fusion power plant. From the viewpoint of plasma density control, it is generally recommended to use different controllers in KSTAR with different diagnostics and actuators. In the KSTAR L-mode, a millimeter wave interferometer (MMWI) [1] measures density of the plasma and a gas puffing (GP) is chosen as corresponding actuator. On the other hand, in the KSTAR H-mode, a far-infrared interferometer (FIRI) [2] is used for measuring H-mode density and supersonic molecular beam injection (SMBI) [3] could be used instead of GP. [4] Using known features and characteristics on the KSTAR L-H transitions, [5, 6] we have made an automatic detector of the L/H transition by Support Vector Machine (SVM) [7], in order to enhance the control efficiency/stability using the  $D\alpha$  drop and the rising gradient of line-averaged electron density. In case of one feature, the prediction model has very low accuracy and, in case of three features, the model has too many samples. Thus, it is desirable to select two features. The prediction model is trained by the SVM with the radial basis function (RBF) kernel. It is found that the kernel has the best accuracy when compared with the other tested kernels through a 5-fold validation. For the calculation speed of detection with acceptable accuracy, the most efficient number of samples has been investigated for a prediction model.

### **References:**

- [1] NAM, Y.U., et al., Rev. Sci. Instrum. 79, 10E705 (2008)
- [2] CHEON, M.S., et al., Rev. Sci. Instrum. 75, 3402 (2004)
- [3] LEE, H.Y., et al., Phys. Plasmas 22, 122512 (2015)
- [4] JUHN, J.-W., et al., Rev. Sci. Instrum. 87, 11E131 (2016)
- [5] WAGNER, F., Plasma Phys. Control. Fusion 49, B1-B33 (2007)
- [6] YOON, S.W., et al., Nucl. Fusion 51, 113009 (2011)
- [7] VAPNIK, V., New York: Wiley (1998)

## **P1/1/10: Coupling plasma control system and pulse schedule editor for WEST operation**

Jacqueline Signoret<sup>1</sup>, Nathalie Ravenel<sup>1</sup>, Rémy Nouailletas<sup>1</sup>, Anett Spring<sup>2</sup>, Manisha Bhandarkar<sup>4</sup>, Marc Lewerentz<sup>2</sup>, Philippe Moreau<sup>1</sup>, Wolfgang Treutterer<sup>3</sup>, Chris Rapson<sup>3</sup>, Heike Laqua<sup>2</sup>

<sup>1</sup>*IRFM, CEA, F-13108 Saint Paul lez Durance, France*

<sup>2</sup>*Max-Planck-Institut für Plasmaphysik, Teilinstitut Greifswald, Wendelsteinstraße 1, D-17491 Greifswald, Germany*

<sup>3</sup>*Max-Planck-Institut für Plasmaphysik, Boltzmannstraße 2, 85748 Garching, Germany*

<sup>4</sup>*Institute for Plasma Research (IPR), Near Indira Bridge, Bhat, Gandhinagar- 382 428, Gujarat*

E-mail of Corresponding Author: [jacqueline.signoret@cea.fr](mailto:jacqueline.signoret@cea.fr)

After 4 years of construction, the WEST platform (W -for Tungsten- Environment in Steady state Tokamak) has entered its operational phase with the first plasma breakdowns achieved in December 2016. WEST is aiming at testing ITER-like components and thus reducing the risks for ITER divertor procurement and operation. For that purpose a new Plasma Control System (PCS) allowing to operate advanced plasma scenarios, associated to a new Pulse Schedule Editor using a time segmented description of the plasma discharge to address real-time handling of plasma and plants events, have been developed. The WEST PCS framework takes its source in the real-time framework called DCS (Discharge Control System) currently used on Asdex Upgrade. The Xedit software has been chosen as Pulse Schedule Editor. It has been developed for the W7X stellarator and fitted to the specifications of the WEST components. After a short description of the adaptations done to fulfill the requirements for WEST, this paper details how the coupling of these two software have been performed and how they have been integrated in the WEST data handling process.

## **P1/1/11: ITER CODAC operation request gatekeeper: first implementation**

D.Stepanov<sup>1</sup>, and M.Vitorovic<sup>2</sup>

<sup>1</sup>*ITER Organization, Route de Vinon-sur-Verdon, CS 90 046, 13067 Saint Paul Lez Durance  
Cedex, France*

<sup>2</sup>*Cosylab d. d., Teslova Ulica 30, 1000 Ljubljana, Slovenia*

E-mail of Corresponding Author: [Denis.Stepanov@iter.org](mailto:Denis.Stepanov@iter.org)

ITER fusion plant is a nuclear facility licensed according to the regulations of its host country, France. Nuclear nature of the project poses constraints on the design of its control system (CODAC), in particular, limits on computer network connectivity and directions of communication. Operation Request Gatekeeper (ORG) is an ITER CODAC concept of controlled communication of plant area with the external world for well-defined cases. The driving principle for ORG operation is that data are submitted and queued at the plant network boundary; plant operators located may fetch the submitted information at their discretion and use, as if it was created inside the plant network.

This contribution will describe work performed in 2016-2017, which was focusing on several areas of interest for early ITER operation. ORG prototype code, done in collaboration with General Atomics in 2009, was rewritten and ported onto current CODAC software platform (Red Hat Linux, Java, PostgreSQL). The application was installed and tested in a model environment implementing network zoning as per IEC 62645 standard recommendations. Two use cases of transfer of machine engineering data (database-based) and scientific data (HDF5 archives) into the outside network were investigated. Another use case included controlled transfer of plasma pulse schedules from the external network into the plant network, for use in the plant scheduling system. Finally, a use case of installing software updates for software developed outside the nuclear perimeter was investigated and demonstrated.

The prepared software addressed high-level application design, focusing on communication patterns and operator workflows. For proper use in a production environment of a nuclear facility it has to be complemented with corresponding lower level cyber-security measures, such as finalized encryption and authentication schemes, and use of unidirectional data replication schemes where appropriate. This is planned as a next phase activity.



## **P1/1/12: Design maturity of plant instrumentation and control for ITER XRCS-Survey**

Sanjeev Varshney<sup>1</sup>, Shivakant Jha<sup>1</sup>, Stefan Simrock<sup>2</sup>, Prabhakant Patil<sup>2</sup>, Vincent Martin<sup>2</sup>, Robin Barnsley<sup>2</sup>, Philippe Bernascolle<sup>2</sup>, Sapna Mishra<sup>1</sup>, Shiddharth Kumar<sup>1</sup>, Vinay Kumar<sup>1</sup>

<sup>1</sup> ITER-India, Institute for Plasma Research, Bhat, Gandhinagar-382 428, Gujarat, India

<sup>2</sup> ITER-Organization, Route de Vinon sur Verdon, CS 90 046, 13067 St. Paul-Lez-Durance, Cedex, France

E-mail of Corresponding Author: [sanjeev@iter-india.org](mailto:sanjeev@iter-india.org)

The X-ray Crystal Spectroscopy (XRCS)-Survey [1] - a broad wavelength band X-ray Crystal spectrometer - is one of the important diagnostic systems delivered by India. It will be installed in the first set of diagnostics on ITER helping the start-up of the plasma operations. The diagnostics is based on X-ray spectroscopy (XRCS) of Hydrogen or Helium like plasma impurity ions of low to high atomic number. The primary function of this system is to measure in real time concentration of the elements polluting the plasma. The plasma impurities are generated due to the interaction of plasma with the plasma facing components. Therefore, this diagnostic system has important function in machine operation such as to protect and/or control the machine during H and D-T phases of the ITER operations.

The design of plant instrumentation and control system for XRCS-Survey is being developed following the mandatory rules described in the Plant Control Design Handbook (PCDH) [2]. The design strategy for PCDH compliant plant I&C system is covered in its guidelines and supported by hardware catalogues. It is therefore important to determine the maturity of the I&C design and its implementation during preliminary and final design review as well as factory and site acceptance testing to ensure its compliance with the PCDH and the diagnostics performance requirements [3]. In order to streamline and standardize the plant I&C design process, the system engineering tool Enterprise Architect (EA) is used with several plug-ins developed by the ITER central team. The plug-ins allows the user to capture requirements, design operation procedures and automation, perform the functional analysis including definition of variables, and finally assess the maturity of the design. This EA plugin has been applied to assess the maturity of the plant I&C system developed for XRCS-Survey system for ITER. The paper will include current design developments of XRCS-Survey plant I&C system for preliminary design review and an assessment of the maturity.

### **References:**

[1] VARSHNEY, S.K. et al, Rev. Sci. Instrum., 83, p 10E126-1 - 3, (2012)

[2] VARSHNEY, S.K et al, Fusion Engineering and Design, 112, p 877, (2016)

[3] SIMROCK, S. et al., Fusion Engineering and Design, 96 - 97, p 952, (2015)

## **P1/1/13: Real-time implementation with FPGA-based DAQ system of a probabilistic disruption predictor from scratch**

J. Vega<sup>1</sup>, M. Ruiz<sup>2</sup>, E. Barrera<sup>2</sup>, R. Castro<sup>1</sup>, G. Rattá<sup>1</sup>, S. Dormido-Canto<sup>3</sup>, A. Murari<sup>4</sup> and JET Contributors\*

*EUROfusion Consortium, JET, Culham Science Centre, Abingdon, OX14 3DB, UK*

<sup>1</sup>*Laboratorio Nacional de Fusión, CIEMAT. Av. Complutense 40. 28040 Madrid. Spain*

<sup>2</sup>*Instrumentation and Applied Acoustic Research Group, Technical University of Madrid, Madrid, Spain*

<sup>3</sup>*Dpto. de Informática y Automática. Juan del Rosal 16. 28040 Madrid. Spain*

<sup>4</sup>*Consorzio RFX. Corso Stati Uniti 4, 35127 Padova, Italy*

E-mail of Corresponding Author: [jesus.vega@ciemat.es](mailto:jesus.vega@ciemat.es)

Real-time (RT) disruption prediction (DP) is essential in fusion to avoid irreversible damage to the devices. Nowadays, physics models for DP are under development and, usually, machine learning methods (with success rate above 90%) are used [1]. However, large training datasets are required but the generation of large databases for DP will not be possible in ITER/DEMO. To overcome this issue, the approach of *prediction from scratch* can be used [2, 3]: adaptive predictors are built from only 1 disruptive and 1 non-disruptive discharge and they are re-trained after each missed alarm.

This paper deals with disruption mitigation and performs the RT implementation of the Venn predictor developed in [3], which provides a probability error bar for each prediction. Results with three ITER-like wall campaigns of JET (1036 non-disruptive and 201 disruptive discharges) show that only 12 re-trainings are necessary, the success rate is 94% and the false alarm rate is 4%.

The RT implementation has been carried out with a fast controller with DAQ FPGA-based data acquisition devices corresponding to ITER catalogue (in particular, a reconfigurable Input/Output platform has been used). Three input signals (sampled at 1 ms) have been used: plasma current, locked mode and internal inductance. These signals are read from JET database. Then D/A conversions are carried out and used as inputs to the data acquisition card. In this way, the whole process of digitization, data analysis and prediction is performed. Predictions are made by using the mean values and the standard deviations of the Fourier spectrum (removing the DC component) of the latest 32 samples of the above signals every 2 ms (prediction period). The Venn predictor uses the nearest centroid taxonomy. The computation time for each prediction takes hundreds of  $\mu$ s.

### **References:**

- [1] VEGA, J., et al., Fusion Engineering and Design. 88, 1228-1231 (2013)
- [2] DORMIDO-CANTO, S., et al., Nuclear Fusion. 53, 113001 (8pp) (2013)
- [3] VEGA, J., et al., Nuclear Fusion. 54, 123001 (17 pp) (2014)

---

\* See the author list of "Overview of the JET results in support to ITER" by X. Litaudon et al. to be published in Nuclear Fusion Special issue: overview and summary reports from the 26th Fusion Energy Conference (Kyoto, Japan, 17-22 October 2016)

## **P1/1/14: Closed-loop control-oriented system identification for EAST plasma shape response model**

Yuehang Wang<sup>1</sup>, Bingjia Xiao<sup>2, 1</sup>, Lei Liu<sup>2</sup>, Yong Guo<sup>2</sup>

<sup>1</sup>*University of Science and Technology of China, Hefei, China*

<sup>2</sup>*Institute of Plasma Physics, Chinese Academy of Sciences, Hefei, China*

E-mail of Corresponding Author: [wagn8901@mail.ustc.edu.cn](mailto:wagn8901@mail.ustc.edu.cn)

The system identification algorithm can build a device-specific control-oriented plasma response model by using measurement data. The EAST shape and position control system <sup>[1]</sup> contains the shape control, slow vertical position (slow Z) control and fast vertical position (fast Z) control. The shape and slow Z controlled by poloidal field (PF) coils and the fast Z controlled by in-vessel coils (IC). Based on the algorithm of EAST shape and slow Z control, we use the system identification method to build a control-oriented plasma shape model with PF coils currents as inputs, flux errors at control point and slow Z error as outputs. In order to obtain better response information, a large number of closed-loop experiments have been designed with using 12 independent PF coils. For each experiment in a set, different PF coil-inputs were excited with suitable input signal, which contains different frequencies and amplitudes. The experimental results have been analyzed by system identification method with Auto-regressive moving-average exogenous input (ARMAX) model and subspace method <sup>[2]</sup> and cross-check has been made between different shot. The global fit of the identification result is 82%.

The identification model is compared with some physics based models, and the multiple-input multiple-output (MIMO) controller is designed based on the identification model.

### **References:**

[1] YUAN, Q., et al., Nuclear Fusion, vol. 53, no. 4, 043009(2013)

[2] LJUNG, L., 13th IFAC Symposium on System Identification, pp. 1802-1807(2003)

## P1/1/15: Radiative feedback for divertor heat spread on EAST

Kai Wu, Bingjia Xiao, Jingbo Chen, Yanmin Duan, Liang Wang, Xinwei Zheng, Zhengping Luo

*Institute of plasma physics, Chinese academy of science, Shushan Road 350, Hefei, Anhui, China*

E-mail of Corresponding Author: [wukai@ipp.ac.cn](mailto:wukai@ipp.ac.cn)

High heat load to the divertor target is one of the critical issues in tokamak fusion reactors or modern tokamaks[1], therefore, active control of heat flux to protect divertor target plates from heat overheating. An effective way is by the aid of radiation in the scrape off layer region. This can be achieved by seeding some minor impurities to increase radiation and exhaust the heat flux[2].

In EAST tokamak, we implemented the active feedback control of radiation power in 2016 experiment campaign. Due to the low latency of the supersonic molecule beam injector (SMBI), we use it as the feedback actuators. Due to difficulty in the divertor region to install SMBI, we can only install it on the midplane. In order to increase further heat spread in front of the divertor target, we used gas puffing valve located on the divertor target as feedforward actuators. PID controller was used as the feedback controller to adjust the SMBI open duration

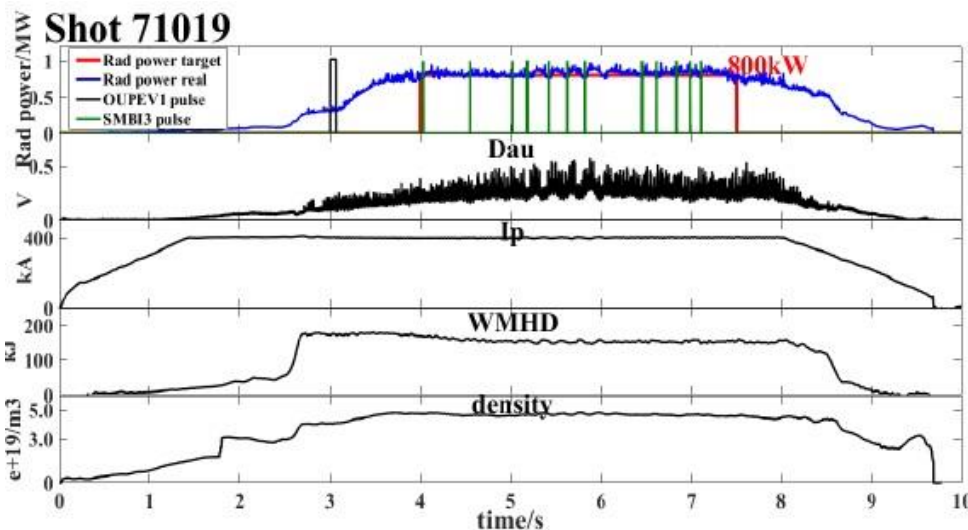

Figure 1, Active feedback control of radiation power.

and frequency for the control of the volume of impurity injection. For the seeding species of SMBI and the divertor gas puff, we all used pure neon.

From figure 1, we can see that the total radiation power can be effectively controlled in either L-mode or H-

mode discharges. The heat flux to the divertor target decreased when the seeding system was working, and the temperature of divertor target plates is kept down, and the stored energy of plasma was just degraded slightly due to impurity seeding. Our control system is effective for the EAST tokamak.

### References:

- [1] IVANOVA-STANIK, I., ZAGORSKI, R., Journal of Nuclear Materials, 463(2015) 596
- [2] TELESKA, G., et al., Nuclear Fusion, Vol. 40, No. 11(2000) 1845

## **P1/1/16: Model-based plasma vertical stabilization and position control at EAST**

B. J. Xiao<sup>1</sup>, R. Albanese<sup>2,4</sup>, R. Ambrosino<sup>3,4</sup>, A. Castaldo<sup>2,4</sup>, G. De Tommasi<sup>2,4</sup>, Z. P. Luo<sup>1</sup>, A. Mele<sup>2,4</sup>, A. Pironti<sup>2,4</sup>, and Q. P. Yuan<sup>1</sup>

<sup>1</sup>*Institute of Plasma Physics, Chinese Academy of Sciences, Hefei 230031, Peoples Republic of China*

<sup>2</sup>*Universit\_a degli Studi di Napoli Federico II, via Claudio 21, 80125, Napoli, Italy*

<sup>3</sup>*Universit\_a degli Studi di Napoli Parthenope, Centro Dir. di Napoli, Isola C4, 80143 Napoli, Italy*

<sup>4</sup>*Consorzio CREATE, via Claudio 21, 80125, Napoli, Italy*

E-mail of Corresponding Author: [bjxiao@ipp.ac.cn](mailto:bjxiao@ipp.ac.cn)

A model-based approach for the design of plasma position and shape control has been recently proposed in [1], aiming at the development of a multi-input-multi-output architecture for integrated plasma shape and flux expansion control at the EAST tokamak. Such an approach exploits the linear models for the response of the plasma and of the surrounding coils derived from the CREATE magnetic equilibrium codes [2, 3]. These linear models have been used for the first time at EAST to design advanced magnetic configuration [4].

During the EAST 2016 experimental campaign the CREATE models have been further exploited to design an alternative approach for plasma vertical stabilization (VS), which is based on the algorithm proposed for ITER [5], and which assures the decoupling between VS and plasma shape control, as required in [1]. Furthermore, the same modeling tools have been used to design the plasma centroid position control, by taking explicitly into account the new VS loop.

In this work we first briefly introduce the adopted model-based design approach, as well as the proposed algorithm for VS and plasma position control. Eventually the results obtained during the 2016 experimental campaign at EAST are discussed. In particular, it is shown that, although the proposed *ITER-like* VS does not control the vertical position, it is capable to stabilize the plasma column using only the in-vessel coils, without the need of the *slow* stabilizing action from the superconductive circuits, as routinely done by the EAST PCS [6].

### **References**

- [1] ALBANESE, R., et al., Proc. of the 2016 Multi-Conference on Systems and Control, 611-616 (2016)
- [2] ALBANESE, R., F. Villone, Nucl. Fus., 38 723{738 (1998)
- [3] ALBANESE, R., et al., Fus. Eng. Des., 96{97 664-667 (2015)
- [4] CALABRO, G., et al., Nucl. Fus., 55 083005 (2015)
- [5] AMBROSINO, G., et al., IEEE Trans. Plasma Sci., 37 1324{1331 (2009)
- [6] YUAN, Q. P., et al., Nucl. Fus., 53 043009 (2013)

*This work has been carried out within the framework of the EUROfusion Consortium and has received funding from the Euratom research and training programme 2014-2018 under grant agreement No 633053. The views and opinions expressed herein do not necessarily reflect those of the European Commission.*

## **P1/1/17: An automation of vacuum system for SMARTEX-C**

Yogesh G. Yeole, Lavkesh Lachhvani, Manu Bajpai

*Institute for Plasma Research, Near Indira Bridge, Bhat, Gandhinagar-382428, India*

E-mail of Corresponding Author: [yogesh@ipr.res.in](mailto:yogesh@ipr.res.in)

An automation of vacuum system for Small Aspect Ratio Toroidal Experiment in C - shaped device (SMARTEX-C [1]) is developed to monitor various parameters and control equipment of the vacuum system. The vacuum requirement for the SMARTEX-C device is  $\sim 1.0 \times 10^{-9}$  mbar. The pressure inside SMARTEX-C vessel is measured by combination of nude ionization gauge and convection enhanced Pirani gauge. The analogue output from ionization gauge as well as convection enhanced Pirani gauge corresponding to pressure values are connected to analogue input of data logger.

Relay cards of different contact current capacity are designed and developed. Data from equipment such as gate valve position status, pressure gauges, and turbo-molecular pump status are monitored, logged, and controlled using relay cards. Various interlocks necessary for vacuum system are designed and implemented using NI USB-6501 DIO module. Software is developed in LabVIEW@[2].

The paper discusses the details of the automation of vacuum system for SMARTEX-C.

### **References:**

- [1] LACHHVANI, L., PAHARI, S., SAXENA, Y.C., J.Phys:Conf.Ser.390 (2012)012047.
- [2] YEOLE, Y.G., et al., Data acquisition and control system for SMARTEX-C, Fusion Eng. Des. (2016), <http://dx.doi.org/10.1016/j.fusengdes.2016.07.010>.

## **P1/1/18: Upgrade of EAST plasma control system for steady-state advanced operation**

Q.P Yuan<sup>1</sup>, J.Y. Tang<sup>1,2</sup>, B. Penafior<sup>3</sup>, R. Johnson<sup>3</sup>, D. Piglowski<sup>3</sup>, R.R. Zhang<sup>1</sup>, B.J Xiao<sup>1,2</sup>, K. Wu<sup>1,2</sup>, Y. Huang<sup>1,2</sup>, Z.P. Luo<sup>1</sup>, Y. Guo<sup>1</sup>, W.T Chai<sup>1,2</sup>, Z.C. Zhou<sup>1,2</sup>, I. Anyanetu<sup>3</sup>, B. Sammulu<sup>3</sup>, M. Kostuk<sup>3</sup>, D.Humphreys<sup>3</sup>, D. Eldon<sup>3</sup>

<sup>1</sup>*Institute of Plasma Physics, Chinese Academy of Sciences, Hefei, Anhui, PR China*

<sup>2</sup>*University of Science and Technology, Hefei, Anhui, PR China*

<sup>3</sup>*General Atomics, DIII-D National Fusion Facility, San Diego, CA, USA*

E-mail of Corresponding Author: [svoboda@jfifi.cvut.cz](mailto:svoboda@jfifi.cvut.cz), [stockel@ipp.cas.cz](mailto:stockel@ipp.cas.cz), [adamek@ipp.cas.cz](mailto:adamek@ipp.cas.cz), [dimitrova@ipp.cas.cz](mailto:dimitrova@ipp.cas.cz)

The EAST plasma control system (PCS), adapted from DIII-D PCS<sup>[1]</sup> and deployed on EAST in 2005, keeps in continuous development and upgrade to achieve major goals of EAST steady-state advanced operation. The hardware upgrades consist of real time data communication between PCS and peripheral data acquisition/processing subsystems, actuator and remote data display systems through the reflective memory (RFM) network<sup>[2]</sup>. Besides, the original cluster internal data exchange network Myrinet is alternated by high speed 10 Giga-bit Ethernet and shared memory communication technology in single multi-core high performance real time node. The operation system (OS) is upgraded to 64-bit linux 6.7 version with strategies applied for real-time customization. The major implementations are explained in this paper. To satisfy EAST steady-state advanced operation, more and more control contents and algorithms are integrated into PCS. The achievements can be summarized as: 1) radiation power successfully feedback controlled by using divertor gas puff and mid-plane supersonic molecular beam injection (SMBI); 2) using low hybrid wave (LHW), loop voltage well controlled and poloidal beta control demonstrated; 3) quasi-snowflake (QSF)<sup>[3]</sup> shape controlled using PEFIT/ISOFLUX, and steady-state ELM-free H-mode QSF discharge achieved with the pulse length up to 20s, about 450 times the energy confinement time; 4) PCS real time data archived using segments into MDSPlus which satisfies EAST 1000 s long pulse operation. In consequences of successive upgrades, the present EAST PCS has become a huge system capable of long pulse, high performance advanced plasma control operation, which is ready to demonstrate ITER-like control contents.

### **References:**

- [1] FERRON, J.R., PENAFLOR, B., WALKER, M.L., et al., Fusion Engineering, vol. 2, p870 (1996).
- [2] YUAN, Q.P., XIAO, B.J., PENAFLOR, B.G., PIGLOWSKI, D.A., LIU, L.Z., JOHNSON, R.D., WALKER, M.L., HUMPHREYS, D.A., Fusion Engineering and Design, Vol. 85, pp.474-477 (2010)
- [3] CALABRO, G., et al., Nucl. Fusion 55, 083005 (2015).



## **P1/1/19: Progress in the development of EAST timing synchronization system upgrade based on precision time protocol**

Z.C. Zhang<sup>1</sup>, B.J. Xiao<sup>1,2</sup>, Z.S. Ji<sup>1</sup>, Y. Wang<sup>1</sup>, P. Wang<sup>1</sup>, and Z.H. Xu<sup>1</sup>

*1. Institute of Plasma Physics, Chinese Academy of Sciences, Hefei, Anhui, 230031, PR China*

*2. Department of Nuclear Science and Technology, University of Science and Technology of China, Hefei, Anhui, 230031, PR China*

E-mail of Corresponding Author: [zzc@ipp.ac.cn](mailto:zzc@ipp.ac.cn)

The timing synchronization system (TSS) plays an important role in Experimental Advanced Superconducting Tokamak (EAST). It's used to provide synchronized sequential triggers and reference clocks for system control and signal measurement. The previous TSS includes a central node and two local nodes, these nodes are all connected by the same path length of optic fibres. With the increasing requirement for triggers, the main problems related to previous version arise when the system has to ensure the path length of optic fibres among the nodes are the same, and the accuracy depends on the fibre traffic conditions and isolation conversion circuits. To solve these problems, upgraded timing synchronization system is developed.

At present, the most accurate way to synchronize distributed data acquisition systems is to use the precision time protocol (PTP) IEEE 1588 2008 standard. The protocol is adopted by EAST CODAC (Control, Data Access and Communication) system to implement the upgraded TSS prototype node consists of a commercial off-the-shelf (COTS) controller, a PXI chassis with PXI-6683 timing module as the time-stamp generator and the RIO (reconfigurable I/O) FPGA devices as the trigger generator. All the nodes with PTP in different places are accessed to timing network by normal network cable, and the timing module on each chassis is synchronized with other IEEE 1588 devices on the network. After synchronize each chassis' 10 MHz backplane clock (PXI\_Clk10) to time reference via PLL (Phase Locked Loop), all nodes share the same backplane clock and the triggers can start/stop at pre-set event time. The strictest synchronization requirements lead to the need of highly accurate clock settings, a satellite-based time server is implemented. Master clock and slave clock in PTP nodes receive universal time information same as GPS (Global Positioning System) time.

The new TSS can provide reference clock in frequency up to 100 MHz with new isolation fan-out devices. The maximum trigger skewing between different nodes is less than 10 ns. The current TSS is more extensible and suitable for the synchronization and timing control of the EAST fusion experiment. It is successfully operating since 2016 EAST experimental campaign. This paper concentrates on the modifications of TSS, the details about the system architecture and test results will be described in this contribution.



## **P1/1/20: Achievements and lessons learned from first operation of KSTAR plasma control system upgrade**

Sang-Hee Hahn<sup>a</sup>, B. G. Penaflor<sup>b</sup>, P.G. Milne<sup>c</sup>, J.G. Bak<sup>a</sup>, N. W. Eidietis<sup>b</sup>, H. Han<sup>a</sup>, J.S. Hong<sup>a</sup>, Y.M. Jeon<sup>a</sup>, R.D. Johnson<sup>b</sup>, H.-S. Kim<sup>a</sup>, HeungSu Kim<sup>a</sup>, Y.J. Kim<sup>a</sup>, W.R. Lee<sup>a</sup>, M.J. Lanctot<sup>d</sup>, J.S. Park<sup>a</sup>, M.H. Woo<sup>a</sup>, B.S. Sammulu<sup>b</sup> and M.L. Walker<sup>b</sup>

<sup>a</sup>*National Fusion Research Institute, Daejeon, Korea*

<sup>b</sup>*General Atomics, San Diego, CA, USA*

<sup>c</sup>*D-TACQ Co. Ltd, Scotland, UK*

<sup>d</sup>*U.S. Department of Energy Office of Science, MD, USA*

E-mail of Corresponding Author: [hahn76@nfri.re.kr](mailto:hahn76@nfri.re.kr)

Results on the first routine operation of the KSTAR plasma control system (PCS) upgrade are given.

In order to transition to a genuine 64-bit system, the CERN MRG-realtime operating system (OS) [1] has been selected as the main real-time OS in order to extend the compatibility with brand-new hardware. A new realtime data streaming scheme[2] has been developed and successfully tested up to 1 million cycles, 50-100 kHz cycle time with ignorable jitters under 1 MHz KSTAR clock. In the first commissioning and routine use performed in 2016, the system was capable of doing full-digital simultaneous feedbacks on 12 power supplies with 10 kHz control cycles respectively, and the analog output units routinely support up to 40 kHz sampling. The upgrade also enabled allowed a doubling of the number of samples per PCS raw data channel so that the system can now acquire more than 400 channels for more than 100 seconds of data with 5 kHz sampling. The performance test results are summarized, featuring In/Out streaming echo tests, operation statistics and the synchronization verifications.

The KSTAR simulator environment[3] has been also migrated to a new faster computing hardware platform, and extended applications of the MATLAB/Simulink-generated algorithms are described with a few examples such as online feedforward trajectory calculations[4] and off-normal fault responses (ONFR)[5]. A new software version management system has been installed for aiding code implementations between distributed sites. Finally, a development plan is briefly given for adding new capabilities desired for KSTAR, including profile controllers utilizing real-time MSE and installation of pellet injectors and a second neutral beam during upcoming campaigns.

### **References:**

- [1] Available at <http://linux.web.cern.ch/linux/mrg/>.
- [2] HAHN, S.-H. et al., *Fus. Eng. Des.*, 112 (2016) 687–691.
- [3] HAHN, S.-H., et al., *Fus. Eng. Des.* 89 (2014) 542–547.
- [4] WALKER, M.L. et al, proceedings in:2016 IEEE Multiconference on Systems and Control, WeA01.2 (2016).
- [5] EIDIETIS, N.W. et al., “Implementing a Finite-State Off-Normal and Fault Response System for Robust Tokamak Operation”, in: 2015 APS DPP meeting 2015.

## **P1/2/01: Implementation of the Fast Plant Interlock System for the ITER Poloidal Field and Central Solenoid Coil's Power Converter protection**

M. Astrain<sup>1</sup>, E. Barrera<sup>1</sup>, M. Ruiz<sup>1</sup>, J. L. Fernandez-Hernando<sup>2</sup>, I. Prieto<sup>3</sup>, R. Pedica<sup>4</sup>, G. Ciusa<sup>4</sup>,  
J. M. Barcala<sup>5</sup>, J. C. Oller<sup>5</sup>, M. Afif<sup>6</sup>

<sup>1</sup>*Instrumentation and Applied Acoustic Research Group, Technical University of Madrid,  
Madrid, Spain*

<sup>2</sup>*ITER Organization, St. Paul-lez-Durance, 13067 France*

<sup>3</sup>*Iberdrola Ingeniería y Construcción S.A.U., 28050 Madrid, Spain*

<sup>4</sup>*Vitrociset, SPA, Via Tiburtina, 1020 - 00156 Roma*

<sup>5</sup>*CIEMAT, Madrid, Spain*

<sup>6</sup>*National Instruments, Austin, Texas USA*

E-mail of Corresponding Author: [mariano.ruiz@upm.es](mailto:mariano.ruiz@upm.es)

The ITER Interlock team has developed a complete methodology [1-2] for the implementation of Fast Plant Interlock Systems (F-PIS) using an embedded FPGA-based solution (cRIO system) and LabVIEW/FPGA as a high level hardware description tool. ITER Interlock Control System (ICS) will be composed of several PIS. One of them, the F-PIS described here, interfaces with several Discharge Loop Interface Boxes (DLIB) and Bypass Loop Interface Boxes (BLIB) of the Power Converters (PC) to protect the magnetic coil integrity and the PCs themselves. Space restrictions in the cubicle, together with a close interaction between DLIB and BLIB related functions, meant designing the system with the added complexity of having to mix different types of digital technologies (24V and TTL) and to implement 19 Safety Functions (in 2oo3 and 1oo1 configurations). Data acquisition module diagnostics and voter diagnostics are implemented using the methodology described in [1]. This is to reduce the Probability of dangerous Failure per Hour (PFH) and maximize reliability and availability. Furthermore, the hardware logic is able to detect system malfunction on either chassis or wrong voter data manipulation inside the FPGA and react in the same loop cycle. The system described uses around 50% of the FPGA resources and response times range from 65  $\mu$ s to 304  $\mu$ s, depending on the function, with an average value of 204.6  $\mu$ s for the 2oo3 SFs.

### **References:**

- [1] BARRERA, E., et al., "Implementation of ITER fast plant interlock system using FPGAs with cRIO". Proceedings of the 2016 IEEE-NPSS Real Time Conference (RT) (20161997). DOI: 10.1109/RTC.2016.7543095.
- [2] Deployment methodology for ITER Fast Plant Interlock Systems. This conference.

## **P1/2/02: The gas supply and gas inlet control systems of the fusion experiment Wendelstein 7-X**

Jörg Schacht, Rudolf Brakel, Steffen Pingel, Heike Laqua, Holger Viebke, Fred Schmidt

*Max Planck Institut für Plasmaphysik, division CoDaC/Device control, Wendelsteinstrasse 1,  
17491 Greifswald*

E-mail of Corresponding Author: [joerg.schacht@ipp.mpg.de](mailto:joerg.schacht@ipp.mpg.de)

After a detailed commissioning process the fusion experiment Wendelstein 7-X (W7-X) was ready to operate in December 2015. In the initial operation phase OP 1.1, which was finished in March 2016, about 950 experiments with technical and physical topics were run.

The gas supply system and the gas inlet system are two important technical systems of the W7-X device, offering a wide spectrum of functions for plasma vessel conditioning, and plasma operation as well as for diagnostic and calibration purposes.

A major design goal was to provide a flexible system for gas fueling and seeding of the plasma, respectively. Other functions are the supply of process gases for cleaning or coating of the plasma vessel, supply of gases or gas mixtures for diagnostic purposes, and nitrogen for flooding of e.g. the plasma vessel and vacuum pumps.

The specific gases required for W7-X operation, hydrogen, deuterium, helium, neon, argon, nitrogen and diborane, are stored by the gas supply system. A valve manifold is the interface between the gas supply system outside of the torus hall and the gas inlet system inside the torus hall. It connects the different gas pipes of the gas supply system with multiple ring lines of the gas inlet system encircling the device.

The gas injection system comprises eleven gas inlets around the torus for controlled injection of working gases into the plasma. This fast system is designed for different operating modes of W7-X, ranging from short discharges with only a few seconds durations to steady state plasma operation with operation time of 30 minutes. Piezo valves as developed by General Atomics are used as fast actuators for the gas inlet system. Furthermore, eight mass flow controller are used for controlling the gas inlet for plasma vessel conditioning and coating.

A brief overview is given of the structure of both gas supply and gas inlet systems. The design of the control systems of the gas supply and the gas inlet are introduced and described. The application of the W7-X gas inlet system is explained in detail during an experiment discharge.

## **P1/2/03: Methodology for the deployment of ITER Fast Plant Interlock System**

E. Barrera<sup>1</sup>, M. Ruiz<sup>1</sup>, M. Astrain<sup>1</sup>, J.L. Fernandez-Hernando<sup>2</sup>, I. Prieto<sup>3</sup>, R. Pedica<sup>4</sup>, G. Ciusa<sup>4</sup>,  
J.M. Barcala<sup>5</sup>, J.C. Oller<sup>5</sup>, M. Afif<sup>6</sup>

<sup>1</sup> *Instrumentation and Applied Acoustic Research Group, Technical University of Madrid,  
Madrid, Spain*

<sup>2</sup> *ITER Organization, St. Paul-lez-Durance, 13067 France*

<sup>3</sup> *Iberdrola Ingeniería y Construcción S.A.U., 28050 Madrid, Spain*

<sup>4</sup> *Vitrociset, SPA, Via Tiburtina, 1020 - 00156 Roma*

<sup>5</sup> *CIEMAT, Madrid, Spain*

<sup>6</sup> *National Instruments, Austin, Texas USA*

E-mail of Corresponding Author: [eduardo.barrera@upm.es](mailto:eduardo.barrera@upm.es)

The fast architecture for the Plant Interlock Systems (PIS) of ITER has been developed based on the use of RIO (Reconfigurable Input/Output) technology from National Instruments (compactRIO platform) [1]. This technology, based on Field-Programmable Gate Arrays (FPGA), allows reconfiguring the hardware taking into account the requirements of each particular system. The ITER Interlock System incorporates several fast PIS, connected to different subsystems such as Coil Power Supply System (CPSS), Ion Cyclotron Heating and Current Drive (ICH&CD), Neutral Beam Injectors and Current Drive (NBI&CD), Disruption Mitigation System (DMS), etc. This implies that each fast PIS configuration must fit each subsystem following a predefined set of rules and allowing different input/output signal types to be handled and different numbers of safety functions (SF) to be performed. This work describes in detail these steps. The methodology incorporates two different phases:

**Development of templates:** This phase implies the design of the hardware description for different configurations, all of them based on cRIO, but incorporating different input/output signals (analog, digital –TTL and 24V-) and providing a configurable number of SF. All of these templates are stored in a SVN repository. For each of them, a specific configuration of the test proof system has been developed to prove their proper operation and to obtain data of its performance.

**Deployment of specific fast PIS:** This phase should be addressed for each particular fast PIS. To do this the hardware modules are assembled into the cRIO chassis according to the system requirements. Based on the case, the corresponding template is downloaded from SVN, opened and then appropriately configured (number of SF, thresholds, default values, etc). Once configured, templates have to be compiled, in order to generate a bitfile. The bitfile is then downloaded to the FPGAs and the system is ready to be tested with the test proof system. Finally, if the system under test meets all the requirements, it can be connected to the sensors and actuators.

This methodology allows deploying the different fast PIS in a secure and controlled way, providing extensively tested systems and reusing the hardware description of previous fast PIS.

### **References**

[1] BARRERA E., et al., “Implementation of ITER fast plant interlock system using FPGAs with cRIO”. Proceedings of the 2016 IEEE-NPSS Real Time Conference (RT) (20161997). DOI: 10.1109/RTC.2016.7543095

## **P2/3/01: Tests results of chopper based integrator prototypes for the ITER magnetics**

A. Batista<sup>1</sup>, L. Capellà<sup>4</sup>, A. Neto<sup>3</sup>, S. Hall<sup>2</sup>, G. Naylor<sup>2</sup>, A. Stephen<sup>2</sup>, J. Sousa<sup>1</sup>, B. Carvalho<sup>1</sup>,  
F. Sartori<sup>3</sup>, R. Campagnolo<sup>3</sup>, I. Bas<sup>5</sup>, B. Gonçalves<sup>1</sup>, S. Arshad<sup>3</sup>, G. Vayakis<sup>6</sup>, S. Simrock<sup>6</sup>,  
and L. Zabeo<sup>6</sup>,

<sup>1</sup> *Instituto de Plasmas e Fusão Nuclear, Instituto Superior Técnico, Universidade de Lisboa,  
1049-001 Lisboa, Portugal*

<sup>2</sup> *CCFE, Culham Science Centre, Abingdon, Oxon, OX14 3DB, U.K.*

<sup>3</sup> *Fusion for Energy, Josep Pla 2, 08019 Barcelona, Spain*

<sup>4</sup> *Vitrociset Belgium Sprl, Gravendijkseweg 53, 2201 CZ Noordwijk, The Netherlands*

<sup>5</sup> *GTD Sistemas de Informacion, 08005 Barcelona, Spain*

<sup>6</sup> *ITER Organization, Route de Vinon-sur-Verdon, CS 90 046, 13067 St. Paul Lez Durance  
Cedex, France*

E-mail of Corresponding Author: [toquim@ipfn.tecnico.ulisboa.pt](mailto:toquim@ipfn.tecnico.ulisboa.pt)

Several design variants of chopper based digital signal integrators have been tested to evaluate the optimal solution to achieve the ITER magnetics diagnostic requirements. A maximum flux-equivalent drift of 500  $\mu\text{V.s/hour}$  is one of the ITER magnetics diagnostic constraints for the integrators. The flux drift must be below the specified limit and simultaneously cope with other stringent specifications such as, 1 kV galvanic isolation, 14-bit ENOB and environment magnetic field tolerance up to 10 mT. This paper presents the results of some of the tests performed to the integrator prototypes developed. These include tests to verify the integrator drift on long experiments when subjected to different conditions, for example, temperature variation, imposition of a common mode voltage and input signals with a frequency spectrum that challenges the design limits.

This work was funded by F4E via contracts F4E-OPE-442 and F4E-OFC-361-08. The views expressed herein are the sole responsibility of the authors and do not necessarily reflect the views of Fusion for Energy, ITER Organization or European Commission. Neither Fusion for Energy nor any person acting on behalf of Fusion for Energy is responsible for the use, which might be made, of the information contained herein.

## **P2/3/02: Refurbishment, consolidation, and real-time enabling of plasma diagnostics using the ASDEX Upgrade SIO/Pipe data acquisition concept**

K.C. Behler<sup>1</sup>, H. Blank<sup>1</sup>, A. Buhler<sup>1</sup>, H. Eixenberger<sup>1</sup>, A. Gude<sup>1</sup>, A. Lohs<sup>1</sup>, K. Lüddecke<sup>2</sup>, M. Maraschek<sup>1</sup>, S. Martinov<sup>1</sup>, R. Merkel<sup>1</sup>, G. Raupp<sup>1</sup>, M. Reich<sup>1</sup>, G. Sellmair<sup>1</sup>, W. Treutterer<sup>1</sup>,  
ASDEX Upgrade Team<sup>1</sup>

<sup>1</sup>*Max-Planck-Institute für Plasmaphysik, Boltzmannstr 2, D-85748 Garching bei München, Germany*

<sup>2</sup>*Unlimited Computer Systems GmbH, Seeshauptstr. 15, D-82393 Iffeldorf, Germany*

E-mail of Corresponding Author: [karl.behler@ipp.mpg.de](mailto:karl.behler@ipp.mpg.de)

The Serial I/O (SIO) data input/output concept combined with the modular “Pipe” based data acquisition (DAQ) periphery is the standard DAQ concept at ASDEX Upgrade since many years [1]. The applicability of this DAQ design for the consolidation of large plasma diagnostics like the Mirnov and Soft-X-Ray diagnostic clusters was one prospect of the continued SIO development. Other goals were its inherent real-time capability and the easy design of custom analogue input modules meeting the “Pipe” backplane form factor. An overview about latest diagnostics renewal activities is given showing the applicability, extensibility, and flexibility of the SIO/Pipe concept for the various purposes. Interface modules to legacy measuring channels as well as new designs of novel medium and high speed analogue to digital converters (ADC's) have been built, or are under design, and roundup the SIO/Pipe toolbox for a widespread collection of needs.

The paper will summarize the work conducted so far and give details of the latest diagnostics built.

### **References**

[1] BEHLER, K., *et al.*, Fusion Engineering and Design 87 (2012), 2145-2151  
<http://dx.doi.org/10.1016/j.fusengdes.2012.09.020>

## **P2/3/03: Design, implementation and commissioning of ATCA based high-speed multichannel data acquisition systems for magnetic diagnostics in W7-X**

B.B. Carvalho<sup>1</sup>, A.Batista<sup>1</sup>, M. Zilker<sup>2</sup>, K. Rahbarnia<sup>3</sup> and the W7-X CoDaC Team<sup>3</sup>

<sup>1</sup> *Instituto de Plasmas e Fusão Nuclear – Laboratório Associado, Instituto Superior Técnico, 1049-001 Lisboa, Portugal, Euratom Association*

<sup>2</sup> *Max-Planck-Institut für Plasmaphysik, Boltzmannstraße 2, 85748 Garching, Germany, Euratom Association*

<sup>3</sup> *Max-Planck-Institut für Plasmaphysik, , Wendelsteinstraße 1, 17491 Greifswald, Germany, Euratom Association*

E-mail of Corresponding Author: [bernardo.carvalho@tecnico.ulisboa.pt](mailto:bernardo.carvalho@tecnico.ulisboa.pt)

The upcoming Fusion experiment of W7-X which is designed to be operated in continuous mode (up to 30 minutes) marks a big challenge for CoDaC developers. High demands are made to the used data acquisition systems concerning performance, interconnect technologies, robustness, reliability, availability and maintainability both from hardware to software. Advanced Telecommunications Computing Architecture (ATCA), a standard originally designed for industry and now being extended to support also applications in physics (xTCA for Physics) covers a lot of the hardware requirements above and seems to be a good choice to design reliable high-performance data acquisition systems. Triggered by the availability of a 32-channel electrically isolated ATCA based ADC board, and a ATCA host controller both designed and produced by Instituto de Plasmas e Fusão Nuclear (IPFN IST), Lisbon, a prototype system was setup and extensively tested, including the resilience to stray magnetic fields in the diagnostic zone of the torus hall. To meet the high demands of Integrators for Magnetic Diagnostics at W7-X a special phase modulated Integrator-ADC-Module was developed which can mitigate the drift which is crucial in long time discharges down to 100 $\mu$ V.s on a 1000 s time interval.

After successful tests the all necessary ATCA boards and ADC-Modules were produced industrially to setup the planned ten complete data acquisition stations for about 300 channels. For the first experimental campaign in OP1.1 already four systems with about 120 channels could be realized, and used routinely for the basic magnetic inductive type diagnostics.

### **References:**

- [1] RAHBARNIA, K.*et al.*, “Commissioning of the magnetic diagnostics during the first operation phase at Wendelstein 7-X”, EPS Conference Leuven, Belgium, July 2016
- [2] KÖNIG, R., *et al.*, “The Set of Diagnostics for the First Operation Campaign of the Wendelstein 7-X Stellarator”, Journal of Instrumentation, October 2015
- [3] WERNER A., “W7-X magnetic diagnostics: Performance of the digital integrator”, Review Scientific Instruments, Volume 77, Issue 10, 2006, <http://dx.doi.org/10.1063/1.2220073>



## **P2/3/04: PCIe Hot-Plug for high-availability ATCA fast controller platform**

M. Correia<sup>1</sup>, J. Sousa<sup>1</sup>, A. P. Rodrigues<sup>1</sup>, B. Santos<sup>1</sup>, P. F. Carvalho<sup>1</sup>, A. Combo<sup>1</sup>, B. B. Carvalho<sup>1</sup>, C. M. B. A. Correia<sup>2</sup>, B. Gonçalves<sup>1</sup>

<sup>1</sup> *Instituto de Plasmas e Fusão Nuclear, Instituto Superior Técnico, Universidade de Lisboa, 1049-001 Lisboa, Portugal*

<sup>2</sup> *LibPhysUC, Departamento de Física, Universidade de Coimbra, 3004-516 Coimbra, Portugal*

E-mails of Corresponding Author: [miguelfc@ipfn.tecnico.ulisboa.pt](mailto:miguelfc@ipfn.tecnico.ulisboa.pt)

High-availability (HA) is a key requirement for upcoming mission-critical systems, as is the case of fast controllers in nuclear fusion. The Advanced Telecommunications Computing Architecture (ATCA) is a hardware platform specification which provides HA resources such as modularity, redundancy, hardware health monitoring and the ability of swapping modules from the crate without having to power off the system (Hot-Swap). A control and data acquisition modular platform for the ITER fast plant system controller (FPSC) has been developed under the ATCA specification. Control and acquisition data are exchanged between modules and the host computer through PCI Express (PCIe). PCIe also provides the capability of its devices to be added and removed from its hierarchy without having to reset or power-off the host. However this is specified for the PCIe adapter form-factor only. The challenge is to implement in the developed ATCA form-factor platform a set of application specific mechanisms that will perform PCIe Hot-Plug, whenever a module is swapped. The paper describes how this implementation was achieved, thus allowing the hardware modules to be inserted or extracted from the crate without having to reset the host computer, significantly improving system availability.

*IST activities received financial support from “Fundação para a Ciência e Tecnologia” through project UID/FIS/50010/2013.*



## **P2/3/05: EPICS data acquisition system for plasma electron density measurement based on FPGA on KSTAR**

Taegu Lee, Myungkyu Kim, Woongryol Lee, Giil Kwon, Taehyun Tak, Junewoo Juhn and Jaesic Hong

*National Fusion Research Institute (NFRI), Daejeon, Republic of Korea*

E-mail of Corresponding Author: [glory@nfri.re.kr](mailto:glory@nfri.re.kr)

The KSTAR has two diagnostics devices of MMWI (Millimeter-wave interferometer) and FIR (Far-infrared interferometer) for measuring plasma electron density. The MMWI diagnostic device measures the electron density of the plasma from the phase difference generated by transmitting an electromagnetic wave having a wavelength of 1 mm (280 GHz) into the plasma. The FIR diagnosis device is the same as the MMWI but uses a far-infrared (119 $\mu$ m) band laser as an electromagnetic wave source. The MMWI diagnostic device measures the L-mode plasma density. However, the signal has a lot of noise from the phase comparator circuit [1].

To avoid the noise from a phase comparator circuit, we developed a new DAQ system using a high-speed digitizer based on FPGA. The MMWI diagnostic device signal is about 10MHz sine wave. We acquired data with 100MSPS using a new digitizer. Thus, the phase difference per sample is 36 degrees, which leads to an inaccurate value with a noise signal. In order to increase the accuracy, the new DAQ system has interpolation logic in the FPGA to increase phase resolution. In addition, the phase comparative value is output to two channels by inverting the signal that is not through the plasma to have a phase difference of 180 degrees. It was constructed with the same algorithm as existing phase comparator circuit using the FPGA [2]. Then, the detected phase is averaged to obtain a phase value, and the result is outputted as 1280 phase values every one msec. In EPICS IOC Host, density is calculated by using data received from the DMA via PCI Express. The above FPGA logic was successful and was used for real-time feedback control in other systems. This paper introduces a detailed design concept of new MMWI DAQ system using FPGA and their operation results.

### **References:**

- [1] TAEGU Lee et al, "New Development of EPICS-Based data Acquisition system for millimeter-wave interferometer in KSTAR tokamak", Proceedings of ICALEPCS2011, Grenoble, France.
- [2] PRAMILA et al, "FPGA based phase detection technique for electron density measurement in SST-1 tokamak", Fusion Engineering and Design 11, 888-891 (2016).

## **P2/3/06: A new implementation of data process in JRTF**

M. Zhang, Y. Li, W. Zheng, G.Z. Zheng, Y. Pan, M. Chen, C. Yang, and J.Y. Xu

*Huazhong University of Science & Technology, Luoyu Road 1037, Wuhan 430074, China*

E-mail of Corresponding Author: [zhengwei@hust.edu.cn](mailto:zhengwei@hust.edu.cn)

J-TEXT real-time framework (JRTF) is the latest development in real-time technology for developing plasma control system and other real-time applications on tokamaks by J-TEXT. It is powered by Linux open source software, fully embraced the object oriented programming technology, and the modular design makes it a promising candidate for developing the prototype of PCS of China Fusion Engineering Test Reactor (CFETR). However, the data sharing between different application blocks (AB) could be time consuming and brings in un-deterministic performance. In this paper, we firstly introduce the framework and the testing device J-TEXT. After that, new method, which is kernel-module programming and the databases technology such as SQLite, is designed. Note that, kernel-module programming skill is to control Linux operating system from kernel space directly, and would have a better real-time performance while data exchange process in theory. We have moved the data sharing process into a kernel module, and managed to squeeze out some performance out of it. In addition, databases technology using in data log process could handle data more systematists. We made a log module based on SQLite of the JRTF, which can be called as a service by every AB. Also, we make searching from all the logs emitted by many AB efficiently. Then, an integration testing has been conducted in order to verify the improvement performance after bringing in such method of data process through kernel-module programming. At the same time, test for SQLite has been executed to test the databases method of logs.

### **References:**

- [1] ZHANG, M., ZHENG, G. Z., ZHENG, W. & CHEN, Z. JRTF: A Flexible Software Framework for Real-Time Control in Magnetic Confinement Nuclear Fusion Experiments. *IEEE Transactions on Nuclear Science* **63**, 1070-1075 (2015).
- [2] NETO, A. et al. MARTe: a Multi-Platform Real-Time Framework. *IEEE Transactions on Nuclear Science* **57**, 479-486 (2010).
- [3] ALVES, D. et al. A New Generation of Real-Time Systems in the JET Tokamak. *IEEE Transactions on Nuclear Science* **61**, 711-719.

## **P2/3/07: Recent developments in video data acquisition, distribution and analysis at ASDEX Upgrade**

S. Martinov, T. Lunt, B. Sieglin, R. Drube, A. Herrmann, and  
ASDEX Upgrade Team

*Max-Planck-Institut für Plasmaphysik, Boltzmannstr. 2, D-85748, Germany*

E-mail of Corresponding Author: [sven.martinov@ipp.mpg.de](mailto:sven.martinov@ipp.mpg.de)

The plasma-facing components (PFCs) of a fusion experiment like ASDEX Upgrade (AUG) are exposed to very large heat fluxes. In order to prevent these PFCs from overheating, cameras sensitive in the near infra-red (NIR) or mid infra-red (IR) are used to monitor their surfaces in real-time. For video acquisition, distribution and analysis four software tools were developed during last years [1, 2].

The central component, a camera framework to acquire and evaluate video data called 'rtCamera' (1) and written in C++ has been designed. It applies commercially available and therefore easily maintainable standard hard- and software from National Instruments for the data acquisition of the cameras via Camera-Link frame grabbers. Furthermore it is optimized for performance and includes functions for filtering and event recognition. Its modular design allows the extension of add-on data processing modules making it applicable for different purposes. Currently it is in use with NIR cameras for machine safety and IR cameras for heat flux calculations. One recent addendum to the framework is the ability to broadcast raw video streams in real-time over the network. JPEG compression and multicast is used for efficient data transfer. This stream is received e.g. by the operators of the different heating systems like NBI, ECRH and ICRH in remotely located control rooms via 'augtv-live' (2). For more in-depth offline analysis the tool 'augtv' (3) is provided. It is highly optimized to the application at a fusion experiment and allows the fast identification of harmful events within the large amounts of data produced by about 30 cameras. An important feature is the inclusion of meta-data from other sources. Part of this meta-data is produced by means of 'augpy' (4), a tool that visualizes the AUG vessel or other devices in 3D and allows the exact identification of the three-dimensional location of the field-of-view of a camera.

The described aspects and tools of the ASDEX Upgrade video acquisition and analysis framework will be presented. A live demo will be given during the poster session.

### **References:**

- [1] DRUBE R. et al. 2013 Fus. Eng. Des. 88 2870-2874.
- [2] MARTINOV S. et al. 2016 Fus. Eng. Des. 112 839-844.

## **P2/3/08: Neutron/Gamma discrimination code based on trapezoidal filter**

R. C. Pereira<sup>1</sup>, A. Fernandes<sup>1</sup>, N. Cruz<sup>1</sup>, J. Sousa<sup>1</sup>, M. Riva<sup>2</sup>, D. Marocco<sup>2</sup>, B. Gonçalves<sup>1</sup>

*1 Instituto de Plasmas e Fusão Nuclear, Instituto Superior Técnico, Universidade de Lisboa,  
1049-001 Lisboa, Portugal*

*2 ENEA, C.R. Frascati, Via E. Fermi, 45-Frascati, 00044 Rome, Italy*

E-mail of Corresponding Author: [ritacp@ipfn.ist.ut.pt](mailto:ritacp@ipfn.ist.ut.pt)

Neutron/gamma discrimination is widely applied in the neutron diagnostics of nuclear fusion tokamak experiments (eg. JET – Neutron Camera diagnostic) and in the up-coming machine, ITER, for instance in the radial and vertical neutron cameras as well as in the compact neutron spectrometer diagnostics. The neutron/gamma discrimination is based on the fact that neutron/gamma detectors output signals have different pulse shaping depending on the impinging event. Several techniques are described in literature such as the charge-integration, curve-fitting and pattern recognition methods.

This paper aims at describing a new technique for neutron/gamma discrimination based on the trapezoidal filter. This technique already implemented in the Field Programmable Gate Array (FPGA) environment for real-time pulse height analyses, targets the FPGA environment implementation, due to its recursive nature. First results will be presented with simulated data where neutron/gamma pulses are simulated with periodic noise and pile-up events. Finally, this algorithm will be applied to real data to prove its feasibility in real-time applications with high event rates.

*IST activities received financial support from “Fundação para a Ciência e Tecnologia” through project UID/FIS/50010/2013.*

## **P2/3/09: MDSplus, FPGA, control and data acquisition system at TCABR Tokamak: small fusion devices contributing with the big experiments**

W.P. de Sá<sup>1</sup>, G. Ronchi<sup>1</sup>, and P.G.P.P. Puglia<sup>1</sup>

<sup>1</sup>*Instituto de Física, Universidade de São Paulo, Rua do Matão, 1371,05508-090 São Paulo, SP, Brazil*

E-mail of Corresponding Author: [pires@if.usp.br](mailto:pires@if.usp.br)

The TCABR is a small tokamak installed at the Plasma Physics Laboratory in the Institute of Physics of the University of São Paulo, Brazil [1]. The obtained experimental data is stored in a MDSplus (Model Driven System Plus) [2] database and the access to the data is performed using tools and libraries available on the MDSplus system. The control, data acquisition, data analysis and remote access (CODAS) of the several different systems present at TCABR [3] has been integrated with MDSplus. Such systems include VME, ATCA, PCs (Linux and MS Windows), oscilloscopes and National Instruments equipment (PXI and USB). Also, there are a Web Logbook and data visualization system run in HTML and MDSplus tools. In future, a FPGA National Instruments system, which is under development, will be used for Alfvén eigenmodes studies with a digital synchronous detection and mode tracking system. This system will be run in LabVIEW and will be fully integrated on the current system. The details of current TCABR CODAS status are presented in this work.

Furthermore, in the past few years there has been an ongoing collaboration between JET and TCABR on the upgrade of the JET active TAE diagnostic system [4]. The upgrade used technologies applied on TCABR experiments and CODAS solutions based on National Instruments equipment and software which were already in use on TCABR. The control and data acquisition of the upgraded system is made using LabVIEW Real-Time software. Details of the system are presented.

### **References:**

- [1] GALVÃO, R., et. al. J. Phys. Conf. Ser. 591 (2015) 012001, doi:10.1088/1742-6596/591/1/012001.
- [2] MANDUCHI, G., FREDIAN, T., STILLERMAN, J., Future directions of MDSplus, Fusion Eng. Des., 89 (5) (2014), pp. 775–779, doi: 10.1016/j.fusengdes.2014.02.012.
- [3] DE SÁ, W.P., RONCHI, G., MDSplus integration at TCABR tokamak: Current status.
- [4] PUGLIA, P., et. al. 2016 Nucl. Fusion 56 112020

## **P2/3/10: Taking advantage of the intercommunication features of IPMCs in ATCA CDAQ systems**

A. P. Rodrigues<sup>1</sup>, M. Correia<sup>1</sup>, B. Santos<sup>1</sup>, P. F. Carvalho<sup>1</sup>, J. Sousa<sup>1</sup>,  
C. M. B. A. Correia<sup>2</sup>, B. Gonçalves<sup>1</sup>

<sup>1</sup> *Instituto de Plasmas e Fusão Nuclear, Instituto Superior Técnico, Universidade de Lisboa,  
1049-001, Lisboa, Portugal*

<sup>2</sup> *LibPhysUC, Departamento de Física, Universidade de Coimbra, 3004-516 Coimbra, Portugal*

E-mail of Corresponding Author: [pinto@ipfn.tecnico.ulisboa.pt](mailto:pinto@ipfn.tecnico.ulisboa.pt)

Control and Data Acquisition (CDAQ) systems applied to large physics experiments like ITER, are designed for high-Availability, acquisition of large amount of data, high transfer rates, real time tasks allowing systems to react in time when critical changes are detected in the plasma parameters. A CDAQ system based on the PCI Industrial Computer Manufacturers Group (PICMG) 3.x AdvancedTCA Base Specification and Intelligent Platform Management Interface (IPMI) standards grants these features.

An Advanced Telecommunications Computers Architecture (ATCA) CDAQ system can be designed implementing the Peripheral Component Interconnect Express (PCIe) standard communication protocol in their fabric lines.

Instituto de Plasmas e Fusão Nuclear (IPFN) has developed and implemented a CDAQ system using the ATCA and PCIe standards.

This paper describes the software architecture and functions implemented in the microcontroller of the Intelligent Platform Management Controller (IPMC) of the ATCA boards in order to bring those standards compatible in what concerns hot-swap and hot-plug processes and several other situations where the intercommunication features of IPMCs through the Intelligent Platform Management Bus-0 (IPMB-0) are used to enhance a CDAQ system using the ATCA and PCIe standards.

*IST activities received financial support from “Fundação para a Ciência e Tecnologia” through project UID/FIS/50010/2013.*

## **P2/3/11: Methodology for the implementation with OpenCL of high performance computing FPGA-based applications using AreaDetector's plugins and EPICS**

M. Ruiz<sup>1</sup>, A. Carpeño<sup>1</sup>, J. Nieto, S. Esquembri<sup>1</sup>, E. Barrera<sup>1</sup>, J. Vega<sup>2</sup>

<sup>1</sup> *Instrumentation and Applied Acoustic Research Group, Technical University of Madrid, Madrid, Spain*

<sup>2</sup> *Laboratorio Nacional de Fusión, CIEMAT. Av. Complutense 40. 28040 Madrid. Spain*

E-mail of Corresponding Author: [mariano.ruiz@upm.es](mailto:mariano.ruiz@upm.es)

Intensive data processing in parallel with the data acquisition process is an obvious necessity in fusion experiments. During the last years, FPGAs have become a very important hardware element for high performance applications because they allow accelerating the execution of mathematical operations using a hardware specifically designed defined by the user for this purpose. The Open Computing Language (OpenCL) is a standardized language that allows the description and implementation of processing algorithms on heterogeneous hardware using CPUs, GPUs and FPGAs as main processing elements [1-2]. On the other hand, EPICS has become an essential platform in the implementation of distributed instrumentation and control systems (I&C) in multiple scientific experiments, and especially in the ITER CODAC system. The integration of DAQ devices into EPICS is being standardized with the use of approach such as AreaDetector [3] or Nominal Device Support. Another advantage of AreaDetector is the option of processing the acquired data by using plugins that use the host CPU capabilities to process the data. In this contribution, we present the methodology for the development of AreaDetector plugins performing the data processing, in an Altera FPGA, using OpenCL as a description language. This approach can be applied into ITER's fast controllers using FPGA-based accelerator cards with PCIe interface. The developed solution has been tested using a SoC-based platform with a Cyclone V FPGA.

### **References:**

- [1] SRIKANTH, S., "Evaluation of 'OpenCL for FPGA' for Data Acquisition and Acceleration in High Energy Physics", J. Phys. Conf. Ser., vol. 664, no. 9, pp. 092023, Dec. 2015.
- [2] SRIKANTH, S., "Accelerating particle identification for high-speed data-filtering using OpenCL on FPGAs and other architectures". Proceedings of the 26th International Conference on Field Programmable Logic and Applications (FPL), 2016.
- [3] ESQUEMBRI, S., RUIZ, M., BARRERA, E., SANZ, D., BUSTOS, A., CASTRO, R., VEGA, J., Implementation of an image acquisition and processing system based on FlexRIO, CameraLink and areaDetector, Fusion Engineering and Design, Volume 112, 15 November 2016, Pages 937-941



## **P2/3/12: Control and data acquisition software upgrade for JET gamma-ray diagnostics**

B. Santos<sup>1</sup>, A. Fernandes<sup>1</sup>, R.C. Pereira<sup>1</sup>, A. Neto<sup>2</sup>, J. Bielecki<sup>3,4</sup>, T. Craciunescu<sup>5</sup>, J. Figueiredo<sup>1,4</sup>, V. Kiptily<sup>4</sup>, A. Murari<sup>4</sup>, M. Nocente<sup>6,7</sup>, D. Rigamonti<sup>6,7</sup>, J. Sousa<sup>1</sup>, M. Tardocchi<sup>7</sup>, L. Giacomelli<sup>6</sup>, I. Zychor<sup>8</sup>, A. Broslawski<sup>8</sup>, M. Gosk<sup>8</sup>, S. Korolczuk<sup>8</sup>, R. Kwiatkowski<sup>8</sup>, A. Urban<sup>8</sup>, G. Boltruczyk<sup>8</sup>, C.M.B.A. Correia<sup>9</sup>, B. Gonçalves<sup>1</sup> and JET Contributors\*

*EUROfusion Consortium, JET, Culham Science Centre, Abingdon, OX14 3DB, UK*

<sup>1</sup>*Instituto de Plasmas e Fusão Nuclear, Instituto Superior Técnico, Universidade de Lisboa, 1049-001 Lisboa, Portugal*

<sup>2</sup>*Fusion for Energy, Josep Pla 2, 08019 Barcelona, Spain*

<sup>3</sup>*Institute of Nuclear Physics Polish Academy of Sciences, PL-31342 Krakow, Poland*

<sup>4</sup>*Culham Centre for Fusion Energy, Culham, United Kingdom*

<sup>5</sup>*Institute of Atomic Physics, Magurele, Ilfov, Romania*

<sup>6</sup>*Dipartimento di Fisica “G. Occhialini”, Università degli Studi di Milano-Bicocca, Milano, Italy*

<sup>7</sup>*Istituto di Fisica del Plasma “P. Caldirola”, CNR, Milano, Italy*

<sup>8</sup>*Narodowe Centrum Badań Jądrowych (NCBJ), 05-400 Otwock, Poland*

<sup>9</sup>*LIBPhys-UC, Department of Physics, University of Coimbra, P-3004 516 Coimbra, Portugal*

E-mail of Corresponding Author: [bsantos@ipfn.tecnico.ulisboa.pt](mailto:bsantos@ipfn.tecnico.ulisboa.pt)

The Joint European Torus (JET), the largest magnetic confinement plasma physics experiment in operation, has a large amount of key diagnostics for physics exploration and machine operation, which include several Gamma-Ray Diagnostics.

The Gamma-Ray Spectrometer (GRS), Gamma Camera (GC) and Gamma-Ray Spectrometer Upgrade (GSU) diagnostics have similar Control and Data Acquisition Systems (CDAQs) based on the Advanced Telecommunication Computing Architecture (ATCA) standard, featuring Field Programmable Gate Arrays (FPGAs) for data processing and management. The installed ATCA CDAQ digitizer boards are connected to the host controller through its Peripheral Component Interconnect Express (PCIe) interface with dedicated in-house developed software drivers.

During past JET-EP2 enhancements, the GRS and GC diagnostics were successfully installed and commissioned. However, the installed CDAQ software that interfaces these diagnostics to JET Control and Data Acquisition System (CODAS) is different, implying higher maintenance costs. While the GRS was implemented using FireSignal, GC used Multi-threaded Application Real-Time executor (MARTe) framework.

Benefiting from the Gamma Camera Upgrade (GCU) and new GSU installation and commissioning, the upgrading of the software and controller hardware used in the GRS and GC was evaluated, aiming at software standardization between all three diagnostics for easier maintenance. The MARTe framework was selected as CDAQ software and Scientific Linux as Operating System (OS).

---

\* See the author list of “Overview of the JET results in support to ITER” by X. Litaudon et al. to be published in Nuclear Fusion Special issue: overview and summary reports from the 26th Fusion Energy Conference (Kyoto, Japan, 17-22 October 2016)



This paper describes the software standardization process between the diagnostics towards the usage of the same CDAQ software as well as the same OS for the controllers, which allows the operator to minimize the maintenance time, avoiding the need for system specific expertise.

*This work has been carried out within the framework of the EUROfusion Consortium and has received funding from the Euratom research and training programme 2014-2018 under grant agreement No 633053. IST activities also received financial support from “Fundação para a Ciência e Tecnologia” through project UID/FIS/50010/2013. The views and opinions expressed herein do not necessarily reflect those of the European Commission.*

## **P2/3/13: A Fiber-optic analog Isolator of up to 10 MHz bandwidth**

Y. Wang, Z. S. Ji, Z. H. Xu, S. Li, Z. C. Zhang

*Institute of Plasma Physics, Chinese Academy of Sciences, Hefei, Anhui, China*

E-mail of Corresponding Author: [wayong@ipp.ac.cn](mailto:wayong@ipp.ac.cn)

The electromagnetic interference (EMI) around the Experimental Advanced Superconducting Tokamak (EAST) device is very harsh during plasma discharge experiment. In order to reduce the effect of EMI and enhance signal to noise ratio (SNR), a fiber-optic high speed isolator has been designed. Each channel of the isolator has a transmitter unit connected via fiber-optic cable to the receiver unit. A transmitter unit consists of a 6<sup>th</sup> order Bessel low-pass anti-aliasing filter, an analog-to-digital converter (ADC), a Field Programmable Gate Array (FPGA), a serializer and an optical transceiver, while a receiver unit comprises an optical transceiver, a deserializer, a FPGA, a digital-to-analog converter (DAC) and a 6<sup>th</sup> order Bessel low-pass filter. Data from the ADC is serialized by the serializer using 8B/10B encoding before transmission, and 10B/8B decoding was used by the deserializer in the receiver unit. A prototype of this isolator has been realized and tested. The test results show that the transmission bandwidth of analog signal is up to 10 MHz, the transmission delay is typically 450 ns, the transmission distance is up to 250 m and the output noise is less than 5 mV, which can meet the requirements of EAST experimental campaigns.

### **References:**

- [1] RATHOD, V.; PARMAR, R.; MANDGE, D., et al., International Conference on Industrial Instrumentation and Control, 687-691 (2015)
- [2] HBM, ISOBE5600, <https://www.hbm.com/en/2343/isobe5600-isolation-system-standalone-transient-recorder>

## **P2/3/14: Current status of EAST data acquisition system**

H.Zwang<sup>1</sup>, S. Li<sup>1</sup>, B.J. Xiao<sup>1</sup>, F. Wang<sup>1</sup>, Y. Chen<sup>1</sup>, F. Yang<sup>1,2</sup>

<sup>1</sup>*Institute of Plasma Physics, Chinese Academy of Sciences, Hefei, Anhui 230031*

<sup>2</sup>*Department of Computer Science, Anhui Medical University, Hefei, Anhui 230030*

At present, EAST data acquisition system has 54 subsystems, total of 3317 channels. Using time slice mode, every 5 seconds will be collected to the real-time transmission of the data to the server, and in accordance with MdsPlus mode<sup>[1][2]</sup>, EAST data acquisition system has achieved long time (1000 seconds) stable data acquisition and data storage. Using Citrix XenServer server virtualization, desktop virtualization, and the use of Citrix XenApp application virtualization, platform based on DELL blade server combined with optical storage and Gigabit network, we also provide 7 x 24 hours data publishing services such as Eastscope, Webscope<sup>[3]</sup>, jscope, Logbook, Eastviewer, Rtscope, Eastvod, RT/offline EFIT, Webportal.

Now EAST data acquisition system has General collection (the sampling rate is less than or equal to 250KSPS): 40 sets, 2857 channels. Speed data acquisition (the sampling rate of 1M/2MSPS): 8 sets, 408 channels. High speed data acquisition (the sampling rate of >2MSPS): 6 sets, 52 channels.

To achieve EAST data acquisition goal, we use Standardized acquisition unit based on PXI Unified development platform, Unified data acquisition software architecture, Multi threaded data acquisition of EAST data<sup>[4]</sup>. After every shot East data acquisition system automatically check the data file is complete; automated testing data access status is normal, web page shows all the data access status. Using virtualization technology to realize cross platform unified remote data access.

### **References:**

- [1] NAKANISHI.H, OHSUNA.M, et al. Data acquisition and management system of LHD. Fusion engineering and design,2010(1):445-457
- [2] BALME.S, Buravand,et al. Real-time data acquisition system for control and long-pulse operation in tore supra. Fusion science and technology,2009(3):1273-1283
- [3] YANG FEI, D.N., XIAO B. WebScope: A New Tool for Fusion Data Analysis and Visualization.Plasma Science and Techology, 2010(2): 253-256
- [4] WANG, F., CHEN, Y., LI, S., CHEN, Y., XIAO, B.J., The demonstration of Lustre in EAST data system, 10th IAEA Technical Meeting on Control, Data Acquisition and Remote Participation for Fusion Research (IAEATM2015, India)

## **P2/4/01: Compression of time-vectors in W7-X archived measurements**

J. G. Krom, R. Daher, T. Bluhm, M. Grahl, M. Grün, C. Hennig, A. Holtz, H. Laqua, M. Lewerentz, H. Riemann, A. Spring, A. Werner and the W7-X Team

*Max Planck Institute for Plasma Physics, Greifswald, Germany*

Wendelstein-7X is, as an stellarator, in principle capable of very long operation. The Control and Data-Acquisitions (codac) systems around w7x have, therefore, been designed for continuous operation. One of the aspects of this design is that the absolute time of every measurement is recorded.

Assorted specialized hard- and software has been developed over the years to support the recording of these times. For every relevant event, e.g. for every sample-clock tick of every adc, we record the time as a 64 bit ("long") integer value. This value is the time since the start of the year 1970, with a resolution of a nanosecond.

The advantages are clear, a high degree of synchronization between all measurements, a high degree of fidelity for each of these time measurements, and highly accommodating towards free running timing systems.

This implies the storage of additional data into the w7x archives. Where most older systems would simply store start-moment, step-size and number-of-samples (or an equivalent triple) for each adc, the w7x approach leads to an extra 8 bytes to be stored for each sample-moment. For an 8 channel, 16 bit adc, this leads to 50% extra data to store. In extreme cases it can even lead to multiplication of the data amounts.

Most of these time-stamps have, on the other hand, a high degree of predictability. It should be possible to compress these data very well.

Normal, de-facto standard, compression approaches (LZW, ZIP, assorted audiocompression algorithms, etc., etc.) perform rather poorly on this type of data; compressing at best with about a factor of two.

Inspired by well-known audio and image compression approaches, we developed a specialized loss-less compression algorithm, aimed at fairly constantly incrementing 64 bit long-integers. Experiments on time data collected in the past demonstrate very large compression factors, whilst retaining all details in the timing data.

## **P2/4/01a: Blue/Green Deployment of W7-X Archive Servers**

J. G. Krom, C. Hennig, M. Grün, T. Bluhm, R. Daher, S. Dumke, M. Grahl, A. Holtz, H. Laqua, M. Lewerentz, H. Riemann, A. Spring, A. Werner, and the W7-X Team

*Max Planck Institute for Plasma Physics, Greifswald, Germany*

E-mail of Corresponding Author: jkrom@ipp.mpg.de

Wendelstein 7-X is, as a stellerator, in principle capable of very long operation. The Control and Data-Acquisitions (CoDaC) systems around W7X have, therefore, been designed for continuous operation. One of the aspects of this design is that all (hard- and software) services of the codac systems must be available “around the clock”.

Most usage of the W7X archives is organised so that a client accesses the archive via a server-process. These clients are, in this context, both data-generators and datausers. Generators such as data-acquisition systems or analysis-processes and users such as display-programs and, again, analysis-processes.

The server process is, in many cases, a program called the “JosDaemon”. The clients communicate with one of these JosDaemons over a bespoke protocol.

In normal operations we have about a dozen server computers for this purpose. On each of these server computers, we normally run one such a JosDaemon. But we can run multiple, fully active daemons on each server computer; potentially daemons of different software versions.

To facilitate software updates of these JosDaemons, without unnecessarily interrupting the overall service, we implemented a mechanism similar to the “Blue/Green Deployment” approach discussed in the “Continuous Delivery” movement [1, 2].

This paper will provide details of our implementation.

### **References:**

- [1] HUMBLE, J., FARLEY, D., “Continuous Delivery: Reliable Software Releases through Build, Test, and Deployment Automation”, 2011, Addison-Wesley.
- [2] FOWLER, M., “Blue/Green Deployment” <https://martinfowler.com/bliki/BlueGreenDeployment.html>

## **P2/4/02: A method for similar waveform search on EAST data**

S. Li, Y. Chen, Y.L. Chen, F. Wang, Y. Wang

*Institute of Plasma Physics, Chinese Academy of Sciences, Hefei, 230031, China*

E-mail of Corresponding Author: [lishi@ipp.ac.cn](mailto:lishi@ipp.ac.cn)

In EAST experimental, to analysis of plasma behavior often need to find some similar waveforms. Current way to look for similar waveforms is to check the structure of wave shape one by one with visual data access tools by researchers. But with increasing experimental data, this approach has been difficult to meet the requirements. In this case, developing automated, efficient similar waveforms retrieval methods become an urgent need. A similar waveform retrieval system based on B/S architecture has been designed. The implementation of similar waveform retrieval system is divided into three parts, offline data processing, real-time similarity retrieval and Web site building. Offline data processing part is implemented on Matlab. This part is to extract the waveform data during discharge, to extract the approximate coefficient as a feature vector by using wavelet transform, and to store the feature into MySQL. Real-time similarity retrieval section is implemented on GPU server. Similarity retrieval is divided into two parts, the first is the calculation of cosine distance with the target ShotNO feature and other ShotNO features in the same signal, the second is to sort the disordered sequence of cosine distance generated by first step and get the ShotNOs of the K's biggest cosine distance as similar ShotNOs. Web site sets up based on the Django framework. It need to interact with the user and show the graphical display of waveform data, graphical display using chart drawing frame Dygraphs, page rendering using asynchronous refresh jQuery and segmentation data request by page turning. By the tests, in view of the similar waveforms retrieval of the whole sequence plasma electric current signal, the match degree of similar waveforms and target waveform is high. The detailed design will be showed in this paper.

## **P2/4/03: The data accessing and processing stack of J-TEXT database cloud**

W. Zheng<sup>1,2</sup>, Q. Liu<sup>1,2</sup>, M. Zhang<sup>1,2</sup>, K.X.Yu<sup>1,2</sup>, Y.X.Wang<sup>1,2</sup>

<sup>1</sup> *State Key Laboratory of Advanced Electromagnetic Engineering and Technology, Huazhong University of Science and Technology, Wuhan 430074, China*

<sup>2</sup> *School of Electrical and Electronic Engineering, Huazhong University of Science and Technology, Wuhan 430074, China*

E-mail of Corresponding Author: [zhangming@hust.edu.cn](mailto:zhangming@hust.edu.cn)

With the fusion experiment data growing rapidly, storing and retrieving the enormous data efficiently is a demanding task [1,2]. J-TEXT Cloud Database (JCDB) is a nuclear fusion experimental data storage and management system, designed to satisfy the requirements of future long pulse experiment. It is assembled by a set of components modularly, including a variety of plug-ins and application programming interfaces, most of which are independent and can be appended or removed by practical situation. To achieve the performance required by future fusion experiment, the data will be divided into chunks, compressed and stored in a distributed data cluster, thus it cannot be accessed by users directly. But with these flexible components, JCDB can provide two approaches of processing and accessing data. The first one is for DAQ device, it streams raw data into database fast by low-level application programming interfaces. The other is for common users who need data been cooked already or presented visually. JCDB will dispatch particular plug-ins to assemble the data in user desired form depending on the requests and the metadata of the required data.

This paper introduces the data accessing and processing of JCDB, including a set of plugins, application programming interfaces, permission management and so on.

### **References:**

- [1] ZHANG, M., et al., Utilizing Cloud Storage Architecture for Long-pulse Fusion Experiment Data Storage, *Fusion Eng. Des.*, 112, 1003-1006 (2016).
- [2] BEHLER, K., et al., Update on the ASDEX Upgrade data acquisition and data management environment, *Fusion Eng. Des.*, 89, 702–706 (2014).

## **P2/4/04: Files syncing and sharing tools for Pellet Injector data handling**

S.Migliori, F.Bombarda, G. G.D'Elia, A.Frattolillo, F.Iannone, S.Podda, F.Poggi

*ENEA Frascati Research Center, via E.Fermi,45, Frascati-Rome 00045 Italy*

E-mail of Corresponding Author: [silvio.migliori@enea.it](mailto:silvio.migliori@enea.it)

The four-barrel, two-stage gun Ignitor Pellet Injector (IPI) was developed in collaboration between ENEA and ORNL to provide cryogenic Deuterium pellets of different mass and speed to be launched into tokamak plasmas with arbitrary timing. The prototype injector is presently located at Oak Ridge (TN, USA), and is normally operated locally through a control and data acquisition system developed in Labview handling multiple subsystems: vacuum, cryogenics, propulsion valves and pellet diagnostics. More recently, a remote-control tool has been set up to fully operate IPI from a control room in Italy providing also to data transfer and store in ENEA ICT storage areas. A Staging Storage Sharing system, named E3S, has been developed over the ENEA ICT infrastructure using Owncloud as architectural component for file syncing and sharing of the IPI data transferred remotely. It provides a homogeneous platform able to store and share heterogeneous data produced by many data acquisition systems in large nuclear fusion experiments like the tokamaks. The cloud storage technology has allowed to design an architecture based on concepts such as: i) data integrity and security, ii) scalability, iii) reliability. A first deployment of E3S works on the pellet facility allowing to store data acquired by the diagnostic systems onto wide area distributed file-system for sharing as well as for remote data access based on MDS+ and Dataturbine tools. The paper presents the first deployment of E3S and a performance analysis of the architectural components. The performance analysis has been carried out with customized benchmark tools on a test bed consisting of a HPC cluster over Infiniband mounting a high performance storage.



## P2/4/05: Data management on technical data of EAST magnets

Jing Qian <sup>a,b</sup>, Yu Wu <sup>a</sup>, B. J. Xiao <sup>a,c</sup>, H. Z. Wang <sup>a</sup>, F. Yang <sup>d</sup>

<sup>a</sup> *Institute of Plasma Physics, Chinese Academy of Science, Hefei, 230031, China*

<sup>b</sup> *University of Science and Technology of China, Hefei, 230026, China*

<sup>c</sup> *School of Nuclear Science and Technology, University of Science and Technology of China, Hefei, 230026, China*

<sup>d</sup> *Department of Computer Science, Anhui Medical University, Hefei, China*

E-mail of Corresponding Author: [jing@ipp.ac.cn](mailto:jing@ipp.ac.cn)

Technical diagnosis system <sup>[1]</sup> (Abbr. TDS) is one of the important subsystems of Experimental Advanced Superconducting Tokamak (Abbr. EAST). In EAST nuclear fusion experiments, TDS monitors technical data such as thermal hydraulic and electric parameters of the superconducting (Abbr. SC) magnets in order to monitor status parameters of EAST and protect the SC magnet system especially during each plasma discharging. It plays an important role of high efficiency and reliability of data management system in TDS data monitoring system <sup>[2]</sup>. System scheme of TDS data management is basically decided by three key factors. The first one is the demand of both local and remote data monitoring and storage. The second one is the function requirements like real-time visualization, online analysis and long-time waveform presentation and so on. The last one is properties of TDS data objects. From data management perspective, TDS data objects are mainly divided into three types which are steady-state data and pulse data and random data. Two-tier data management system architecture is adopted with both local databases and remote databases to satisfy different usages and real-time data processing demands. And three-type databases are applied in TDS data management system, which are micro-soft SQL Server database used for configuration of each signal channel and arithmetic operations and for long-time steady-state data storage, mySQL database for real-time data web presentation and MDSplus database for online data analysis and long-pulse data waveform presentation <sup>[3]</sup>. In the paper it is described of the implementation of each type of database applied in TDS data management system. Three key difficulties during the implementation are put to highlights. Future development is also introduced. It proved in past experiments that the TDS data management system cannot only deal with large volume data efficiently but also satisfy kinds of function requirements.

### References:

[1] QIAN, J., et al., Fusion Engineering and Design. 85 828–835 (2010)

[2] QIAN, J., et al., Nuclear Science and Techniques. 21 187-192 (2010)

[3] YANG, F., et al., Fusion Engineering and Design. 87 2161-2165 (2012)

## **P2/4/06: Tools to export machine-readable datasets from IDL, $\pi$ Scope and MATLAB**

S. Shiraiwa, M. Greenwald, J.A. Stillerman, G.M. Wallace, M.R. London, J. Thomas

*MIT Plasma Science and Fusion Center, 190 Albany St Cambridge, 02139, USA*

E-mail of Corresponding Author: [shiraiwa@psfc.mit.edu](mailto:shiraiwa@psfc.mit.edu)

This paper presents the efforts at PSFC to comply with a new directive from the White House Office of Science and Technology Policy, which requires that all publications supported by federal funding agencies (e.g. Department of Energy Office of Science, National Science Foundation) include machine-readable datasets for figures and tables. The memorandum [1] includes a specific language saying that the data must be “stored and publicly accessible to search, retrieve, and analyse”, which disfavors the use of proprietary formats such as an IDL save set and encourages the use of more openly available data formats. The manual effort required for producing a well-documented, and therefore potentially useful, data set is not trivial. At PSFC, we defined a standard schema for data and metadata to comply the new open data requirement along with procedures in several commonly used scientific languages (IDL, MATLAB, Python) for generating an HDF5 format output for our common data analysis environments.

$\pi$ Scope is a python data analysis environment, which allows a user to generate publication quality graphics seamlessly from MDSplus data system [2]. It allows a user to edit, annotate, and save Matplotlib figures. All plot commands in  $\pi$ Scope accept a keyword to define a graphics metadata at plotting. It also equipped with a newly added interactive interface to HDF5 metadata export, which collects metadata from an existing figure and allows user to edit them. As for MATLAB, we developed a fully automated MATLAB script, which extracts the data and metadata from a .fig file and exports it into HDF5. This script requires no additional user input, resulting in quick and convenient data file generation, but is less flexible in terms of controlling the variety of metadata in the file.

The PSFC library must now manage and distribute the collection of files associated with each manuscript. A web based document submission and distribution system has been developed for this. Authors provide additional files and metadata with their manuscript, and these are in turn archived with the manuscript in Harvard Dataverse, MIT DSpace and DoE Pages.

### **References:**

[1] HOLDREN, J.P.. “Increasing Access to the Results of Federally Funded Scientific Research.” Feb. 22, 2013, <https://obamawhitehouse.archives.gov/blog/2016/02/22/increasing-access-resultsfederally-funded-science>.

[2] SHIRAIWA, S. et. al., Fusion Engineering and Design 112, 835-838 (2016).

## **P2/5/01: Software parallelization of a probabilistic classifier based on Venn prediction: application to the TJ-II Thomson Scattering**

F. J. Martinez<sup>1</sup>, J. Vega<sup>2</sup>, S. Dormido-Canto<sup>1</sup>, I. Pastor<sup>2</sup>, E. Fabregas<sup>1</sup>

<sup>1</sup> *Departamento de Informática y Automática, UNED, Madrid 28040, Spain*

<sup>2</sup> *Laboratorio Nacional de Fusión. CIEMAT, Madrid 28040, Spain*

E-mail of Corresponding Author: [efabregas@bec.uned.es](mailto:efabregas@bec.uned.es)

One of the recurring problems encountered in the development of automatic classification problems has been called the “*curse of dimensionality*”. Procedures that are computationally manageable in low dimensional spaces can become unfeasible in spaces of hundreds of dimensions due to the need of long computational times. A potential solution for this can be the use of high performance computing (HPC) [1]. This paper shows the parallelization of a probabilistic classifier based on Venn Predictors (VP) [2]. VP determine a probability interval to qualify how accurate and reliable each individual classification is. To this end, the Venn predictor divides all examples into a number of categories. To carry out this division, VP uses a taxonomy function that classifies the relation between an example and the set of the other examples. In particular, this work has used a taxonomy derived from a Support Vector Machine classifier.

The parallelized code has been applied to the classification of the images from the CCD camera of the TJ-II Thomson Scattering. There are 5 classes of images corresponding to a) CCD camera background (BCK), b) measurements of stray light without plasma or in a collapsed discharge (STR), c) images during ECH phase in TJ-II (ECH), d) image during NBI phase in TJ-II (NBI) and e) image after reaching the cut-off density during ECH heating in TJ-II (COFF). The images have 576 x 385 pixels and, therefore, the classification problem deals with feature vectors of dimensionality  $O(10^5)$ . To alleviate the “*curse of dimensionality*” a Haar wavelet transform at the level 4 of decomposition has been used (approach and vertical coefficients). This level allows both removing redundant information between adjacent pixels (they are highly correlated) and retaining coarse image information. A set of 1149 images (107 BCK, 205 STR, 461 ECH, 334 NBI and 42 COFF) has been used as training dataset and 999 images (77 BCK, y 175 STR, 431 ECH, 304 NBI and 12 COFF) have been used for test purposes. By using taxonomies with 8 categories and a classification approach of one-versus-the-rest, the success rate has been 96.58%. The average probability and probability interval are respectively 0.94 and 0.04 (that means a very efficient prediction from the prediction perspective, because large probability intervals (in an extreme case [0, 1]), are completely uninformative). The time saved with the parallelization has been a factor of 18.

### **References:**

- [1] RAMÍREZ, J. et al. Fusion Engineering and Design. 85 (2010) 425-427.
- [2] VOVK, V., A. Gammerman, G. Shafer. “Algorithmic learning in a random world”. Springer (2005).

## P2/5/02: Applying deep learning for improving image classification in fusion

G. Farias<sup>1</sup>, J. Vega<sup>2</sup>, S. Dormido-Canto<sup>3</sup>, K. Hidalgo<sup>1</sup>, S. Vergara<sup>1</sup>, E. Fábregas<sup>3</sup>

<sup>1</sup> Pontificia Universidad Católica de Valparaíso, Av. Brasil 2147, Valparaíso, Chile

<sup>2</sup> Laboratorio Nacional de Fusión, CIEMAT, Av. Complutense 40. 28040 Madrid, Spain

<sup>3</sup> Dpto. de Informática y Automática, UNED, Juan del Rosal 16. 28040 Madrid, Spain

E-mail of Corresponding Author: [gonzalo.farias@pucv.cl](mailto:gonzalo.farias@pucv.cl)

Deep learning has emerged as one of most encouraged approaches in recent past years. One of the main applications of deep learning is the automatic feature extraction with autoencoders. Feature extraction is a very critical stage in machine learning that can reduce drastically the dimensionality of the problem, making easier the process of classification [1].

This article addresses the assessment of including autoencoders for automatic feature extraction in the massive thermonuclear fusion databases. In order to show the performance of autoencoders in a practical way, the problem of the classification of a set of 981 images of the TJ-II Thomson Scattering diagnostic has been selected. Similar to other pattern recognition problems, in this case there are two main stages: i) the pre-processing of the data, and ii) the application of a classification algorithm to get a model [2]. Thus, the autoencoders are just added between both two stages to extract features from the pre-processed images. The classification has been performed by the algorithm of support vector machines, but it should be clear that the selection of a different method for this step should produce similar results. The work evaluates three main questions of using autoencoders for the classification of images: i) are the models more accurate? ii) are the predictions computed faster?, and iii) are the models better fitted for new images?.

The results show that the use of autoencoders produces models with higher success rates, reaching in some cases up to 96% in average, which is 2% over the performance without autoencoders. The results also show that model predictions can be computed in less time when autoencoders are used. The models can be twice faster than the cases without autoencoders, although it could require parallel programming of autoencoders for operation in real-time. Finally, in order to confirm that the classifiers with autoencoders are more robust and better fitted for new images, a conformal predictor was developed to add confidence values to the classification. The results show that classifiers with autoencoders are able to make predictions for new images with up to 50% more of confidence and credibility.

### References:

[1] LE, Q. V. IEEE International Conference ICASSP, pp. 8595-8598 (2013).

[2] DORMIDO-CANTO, S., *et al.*, *Review of scientific instruments*, 75, 10, 4254-4257 (2004).

## **P2/5/03: Image classification by using a reduced set of features in the TJ-II Thomson Scattering diagnostic**

G. Farias<sup>1</sup>, S. Dormido-Canto<sup>2</sup>, J. Vega<sup>3</sup>, I. Martinez<sup>1</sup>, E. Fábregas<sup>2</sup>

<sup>1</sup> *Pontificia Universidad Católica de Valparaíso, Av. Brasil 2147, Valparaíso, Chile*

<sup>2</sup> *Dpto. de Informática y Automática, UNED, Juan del Rosal 16. 28040 Madrid, Spain*

<sup>3</sup> *Laboratorio Nacional de Fusión, CIEMAT, Av. Complutense 40. 28040 Madrid, Spain*

E-mail of Corresponding Author: [gonzalo.farias@pucv.cl](mailto:gonzalo.farias@pucv.cl)

During the past few years, machine learning has been increasingly applied for developing pattern recognition systems in massive thermonuclear fusion databases. Several solutions can be found in the literature for fast retrieval information, classification and forecasting of different types of waveforms [1]. Images in fusion are not the exception, there are some data-driven models that have been successfully implemented to classify Thomson Scattering images in the TJ-II stellerator [2-3]. Most of these image classifiers were developed by using data mining techniques such as neural networks and support vector machines. One advantage of these techniques is that they only require a set of inputs (images) and their corresponding outputs (the class of each image) to learn a function that outputs the class to a new input image. This decision function is so complex and non-linear that it is normally called a black box model, and although this approach could perform a one hundred percent of success classification, it is not able to provide a clue of the reason for such output.

This work proposes the use of boosting algorithms to build models that provides very simple IF-THEN rules to classify Thomson Scattering images. Boosting is a way to improve the model by adding a simple rule that assigns correctly classes to some previously wrong classified samples. Thus, the obtained model is an explicit weighted sum of several simple rules that could provide useful information about why an image has been assigned to a particular class. The article also shows that even using a reduced set of pixels (less than 0.1% of the original image) the classifier is able to keep a high success rate (over 95%). As it will be shown, such aspect produces three important benefits: i) a reduction of the computational time for classification, ii) a more robust performance in noisy conditions (stray light), and finally iii) a way to support knowledge discovery from the five different classes of the TJ-II Thomson Scattering images.

### **References:**

- [1] VEGA, J., *et al.*, Fusion Engineering Design, 81 2045-2050 (2006)
- [2] FARIAS, G., *et al.*, Lecture Notes in Computer Science, 3562, 2, 604-612 (2005)
- [3] MAKILI, L., *et al.*, Fusion Engineering Design, 85, 3-4, 415-418 (2010)

## **P2/5/04: New FPGA processing code for JET gamma-ray camera upgrade**

A. Fernandes<sup>1</sup>, R. C. Pereira<sup>1</sup>, B. Santos<sup>1</sup>, J. Bielecki<sup>2,3</sup>, G. Boltruczyk<sup>4</sup>, A. Broslawski<sup>4</sup>, P.F. Carvalho<sup>1</sup>, J. Figueiredo<sup>1,3</sup>, L. Giacomelli<sup>6</sup>, M. Gosk<sup>4</sup>, V. Kiptily<sup>3</sup>, S. Korolczuk<sup>4</sup>, R. Kwiatkowski<sup>4</sup>, A. Murari<sup>3</sup>, M. Nocente<sup>5,6</sup>, D. Rigamonti<sup>5,6</sup>, J. Sousa<sup>1</sup>, M. Tardocchi<sup>6</sup>, A. Urban<sup>4</sup>, I. Zychor<sup>4</sup>, C.M.B.A. Correia<sup>7</sup>, B. Gonçalves<sup>1</sup> and JET Contributors\*

*EUROfusion Consortium, JET, Culham Science Centre, Abingdon, OX14 3DB, UK*

<sup>1</sup> *Instituto de Plasmas e Fusão Nuclear, Instituto Superior Técnico, Universidade de Lisboa, 1049-001 Lisboa, Portugal*

<sup>2</sup> *Institute of Nuclear Physics Polish Academy of Sciences, PL-31342 Krakow, Poland*

<sup>3</sup> *Culham Centre for Fusion Energy, Culham, United Kingdom*

<sup>4</sup> *Narodowe Centrum Badań Jądrowych (NCBJ), 05-400 Otwock, Poland*

<sup>5</sup> *Dipartimento di Fisica “G. Occhialini”, Università degli Studi di Milano-Bicocca, Milano, Italy*

<sup>6</sup> *Istituto di Fisica del Plasma “P. Caldirola”, CNR, Milano, Italy*

<sup>7</sup> *LibPhys-UC, Department of Physics, University of Coimbra, P-3004 516 Coimbra, Portugal*

E-mail of Corresponding Author: [anaf@ipfn.tecnico.ulisboa.pt](mailto:anaf@ipfn.tecnico.ulisboa.pt)

The 2D gamma-ray camera of the Joint European Torus (JET) is one of the target diagnostics for physics exploitation during next high-power deuterium-tritium experiments. From the gamma-ray emission spectra, associated with specific reactions among fast ions and fusion alphas with impurities, it will be possible to infer information on the spatial distribution of these fast ions and alpha particles, and to follow their evolution in time. The Gamma Ray Camera Upgrade (GCU) project is devoted to the installation of a new set of 19 scintillators, with a short decay time and a multi-pixel photon counter (MPPC) embedded. These fast scintillators were designed to cope with the high fluxes expected during deuterium-tritium plasmas while improving the diagnostic spectroscopic capabilities. GCU will benefit from the Advanced Telecommunications Computing Architecture (ATCA) based Data Acquisition System (DAQ), successfully installed and commissioned during the JET-EP2 enhancement. The DAQ modules include reconfigurable Field Programmable Gate Array (FPGA) devices, being capable to acquire and real-time process the 19 Lines-Of-Sight (LOS), returning only the useful information. To cope with the new GCU detector signals, the DAQ FPGA code needs to be rebuilt. This work presents the FPGA code upgrade for DAQ gamma camera, capable to sustain the expected fast response of new detectors, while exploiting the full capabilities of the DAQ. Dedicated codes were designed, capable to acquire the new signals at full rate, and simultaneously processing it in real-time through suitable algorithms, fitted to the new signal shape. First results of real-time processing codes applied to data from detector prototypes are presented.

*This work has been carried out within the framework of the EUROfusion Consortium and has received funding from the Euratom research and training programme 2014-2018 under grant agreement No 633053. IST activities also received financial support from “Fundação para a Ciência e Tecnologia” through project UID/FIS/50010/2013. The views and opinions expressed herein do not necessarily reflect those of the European Commission.*

---

\* See the author list of “Overview of the JET results in support to ITER” by X. Litaudon et al. to be published in Nuclear Fusion Special issue: overview and summary reports from the 26th Fusion Energy Conference (Kyoto, Japan, 17-22 October 2016)



## **P2/5/05: A visualization tool for EAST diagnostic profiles data**

R.R. Zhang<sup>1</sup>, B.J. Xiao<sup>1,2</sup>, Y. Liu<sup>1</sup>, F. Yang<sup>1,3</sup>, G.Q. Li<sup>1</sup>, Y.L. Qin<sup>1</sup>

<sup>1</sup>*Institute of Plasma Physics, Chinese Academy of Sciences, Hefei 230031, China*

<sup>2</sup>*School of Nuclear Science and Technology, University of Science and Technology of China, Hefei 230031, China*

<sup>3</sup>*Department of Computer Science, Anhui Medical University, Hefei 230030, China*

E-mail of Corresponding Author: [rrzhang@ipp.ac.cn](mailto:rrzhang@ipp.ac.cn)

EAST is a complex and highly coupled device consisting of dozens of diagnostics and several subsystems (auxiliary heating, fueling, cryogenic, power, etc.). The quasi-real-time and full sharing of experiment data (raw data, processed data and simulation results) and resources (data viewing and analysis software, simulation tools, etc.) is a prerequisite for effective engineering and physical experiments. A more complete EAST processed data database has been established on the basis of Mdsplus data storage and access platform. The experiment data from routine diagnostics is analyzed automatically by a suite of codes within minutes after operation at EAST<sup>[1]</sup>. A tool allows the easy visualization of diagnostic profiles data in EAST is described in this paper. It provides a uniform interface and rich functions (navigation, zoom, crosshair, overlay, etc) to quickly access and compare the profile (temperature, density, impurity, etc) from various diagnostic systems under different coordinate modes (r/z, flux surface coordinates psi or rho). Python combined with PyGTK toolkit is used to make it support cross-platform and be disturbed freely. It can be used for rapid plasma analysis, especially in the control room during operation. The implementation detail will be described in this paper.

### **References:**

[1] YANG, F., et al. (2014). "Construction and Implementation of the Online Data Analysis System on EAST." *Plasma Science & Technology* 16(5): 521-526.

## **P2/5/06: An adaptive disruption predictor for avoidance/mitigation purposes**

G.A. Rattá<sup>1</sup>, J. Vega<sup>1</sup> and JET Contributors\*

*EUROfusion Consortium, JET, Culham Science Centre, Abingdon, OX14 3DB, UK.*

<sup>1</sup>*Laboratorio Nacional de Fusión. CIEMAT, Madrid, Spain.*

High energy disruptions can provoke considerable damages to plasma facing components in tokamaks [1]. On the other hand, in plasmas with lower energy loads, the expected consequences are less critical. During experimental campaigns, it can be useful to have different options of predictive protection systems according the expected severity of a potential disruption.

In this article, a machine learning prediction methodology based on Genetic Algorithms [2] has been developed. It allows adjusting a predictor by assigning higher/lower scores during the computational optimization process to make it more/less sensitive to the recognition of disruptive conditions. As a consequence, it can trigger more (and with longer anticipations) or less alarms according to the operational needs.

As proof of principle, two different settings have been tested. In the first one, a low false alarms rate was generously rewarded and its performance was similar to previous machine learning based predictors [2], with controlled percentages of false alarms (5,6%) and detections over 90% (with at least 10 ms of anticipation), and 50% (with at least 100 ms of anticipation). The second setting targeted the avoidance of disruptions, which requires larger warning times. For that, greater rewards were assigned for early anticipations (at least 100 ms). As result a predictor more susceptible to trigger alarms was obtained. In this case, significant improvements in the detection rates, 97.5% and 65.2% for 10 ms and 100 ms of warning times respectively, coincided with a considerable increment of the false alarms (30.6%). This response was the expected one since the predictor was set to indicate detections at the first sign of possible disruptive plasma behaviour.

To get these results, both predictors were tested under a realistic real-time simulation with a large (2331 pulses, 362 of them disruptives) and independent (the group of testing pulses is completely different of the one use to create the predictors) database from JET to guarantee their reliability.

### **References:**

[1] RICCARDO, V., et al., Nuclear Fusion. 45, 1427 (2005).

[2] RATTÁ, G.A., et al. Fusion Engineering and Design Volume 112, 15pp 1014–1018 (2016).

---

\* See the author list of “Overview of the JET results in support to ITER” by X. Litaudon et al. to be published in Nuclear Fusion Special issue: overview and summary reports from the 26th Fusion Energy Conference (Kyoto, Japan, 17-22 October 2016).



## **P2/6/01: Web-based discharge scenario query system on EAST**

W.T Chai<sup>1,2</sup>, B.J Xiao<sup>1,2</sup>, Q.P Yuan<sup>1</sup>, R.R. Zhang<sup>1</sup>, and S.L Chen<sup>1</sup>

<sup>1</sup>*Institute of Plasma Physics, Chinese Academy of Sciences, Hefei, Anhui, PR China*

<sup>2</sup>*University of Science and Technology, Hefei, Anhui, PR China*

E-mails of Corresponding Author: [wchai@ipp.ac.cn](mailto:wchai@ipp.ac.cn)

The discharge scenario query system, designed and deployed since 2014, is an important part of EAST remote discharge scenario management system (RDSMS) [1]. The pre-set parameters analysis and extraction is the key technology for scenario classification and query. On EAST, the pre-set parameters can be parsed line-by-line from future shot files or MDSplus tree node for history shots through a variety of type conversions. The storage structure and parsing procedure of pre-set parameters will be introduced in this paper. Take advantage of parsing procedure, the wave data or block data which direct pre-set parameters have been acquired and stored to the database. Combined with history shot data analysis, the representative shot information for some typical discharges will be recorded in the database for further advanced scenario query. In order to provide a cross platform tool, a remote graphical user interface has been built in form of dynamic Web page to query and evaluate parameters. This web-based discharge scenario query system will ultimately lead to improved work efficiency of physical operators.

### **References:**

[1] CHAI, W.T., XIAO, B.J., YUAN, Q.P., ZHANG, R.R., The design of remote discharge scenario management system on EAST, Fusion Engineering and Design, 112 (2016) 1049-1054.

## **P2/6/02: Distributed collaborative environment for software applications**

S. Dormido-Canto<sup>1</sup>, J. Vega<sup>2</sup>, J. Chacón<sup>1</sup>, E. Fábregas<sup>1</sup>, G. Farias<sup>3</sup>

<sup>1</sup> *Dpto. de Informática y Automática, UNED, Juan del Rosal 16. 28040 Madrid, Spain*

<sup>2</sup> *Laboratorio Nacional de Fusión, CIEMAT, Av. Complutense 40. 28040 Madrid, Spain*

<sup>3</sup> *Pontificia Universidad Católica de Valparaíso, Valparaíso, Chile*

E-mail of Corresponding Author: [sebas@dia.uned.es](mailto:sebas@dia.uned.es)

This paper shows the implementation of a robust and generic collaborative system that allows the execution of applications in heterogeneous and distributed environments. In particular, it is related to the application and dissemination of advanced methodologies in relation to machine learning methods in the field of nuclear fusion. The collaborative environment will allow authorized users to launch applications in an easy and totally transparent way. The expression “totally transparent” means that the applications will be hosted by any computational resource that belongs to the collaborative environment and the user only has to provide his input data. The distributed collaborative environment (including high performance computing) will be accessible from web resources. The generated software repository will be an open space that includes all the implemented methods. For large problems with high data dimensionality, parallel software is available. But it is important to mention the existence of a strict policy of use in relation to CPU time allowed for the works. The distributed collaborative environment will have HPC systems (in CIEMAT and UNED) and several individual computational nodes can be located in several research centres. The management of users and resources will be implemented with generic Web services [1], [2] or dedicated services as Emersion [3]. Obviously the security requirement will be implemented using an authentication and authorization mechanism.

### **References:**

- [1] FARIAS, G., *et al.*, IEEE Trans. On Industrial Electronics, 57, 10, 3266-3275 (2010)
- [2] VEGA, J., *et al.*, Fusion Engineering Design, 81 2045-2050 (2006)
- [3] DORMIDO, R., *et al.*, IEEE Trans on Education, 51, 1, 35-44 (2008)

## P2/6/03: Preliminary realization of immersive EAST system using virtual reality

D. Li<sup>1</sup>, B.J. Xiao<sup>1,2</sup>, J.Y. Xia<sup>1,3</sup>, and K.R. Wang<sup>1</sup>

<sup>1</sup>*Institute of Plasma Physics, Chinese Academy of Sciences, Hefei, Anhui, China*

<sup>2</sup>*School of Nuclear Science and Technology, University of Science and Technology of China, Hefei, Anhui, China*

<sup>3</sup>*University of Science and Technology of China, Hefei, Anhui, China*

E-mail of Corresponding Author: [lidan@ipp.ac.cn](mailto:lidan@ipp.ac.cn)

Aiming at the complex and confined environments of experimental advanced superconducting tokamak (EAST) and the need to improve the working ability of the scientists, the immersive EAST system based on virtual reality is developed. Compared to previous virtual EAST systems [1-3], model reality, rendering speed, immersion and interaction types are greatly increased. In the previous system, models are transformed from CATIA and imported to 3DS Max for subsequent processing, although those models are very precise or easily to be generated, these advantages come at the price of decreased rendering speed and poor rendering quality because of a large loss of triangle faces. In this regard, EAST models are rebuilt and materials created by photos of EAST device are assigned to models. Moreover, given that the effect of virtual reality at creating experiment scenarios due to their ability to provide immersive operation feeling and collaborative environments, model libraries are built during the research for future scheme generation and training of parts installation. The immersive EAST system is developed in the Unity3D using a client-server architecture, the HTC Vive and handles are used to provide immersive scene, intuitive controls and realistic haptic feedback. Users can roam in the virtual scene and interact with the immersive EAST using the handles, communicate with other users in the system. The establishment of the system provides the framework basis for a comprehensive and cooperative experiment and training environment for EAST.

### References:

- [1] LI, D., *et al.*, Fusion Eng. Des. **89**, 736-740 (2014)
- [2] LI, D., *et al.*, Fusion Eng. Des. **112**, 850-855 (2016)
- [3] XIA, J.Y., *et al.*, Fusion Eng. Des. **112**, 946-951 (2016)

## P2/6/04: Improvement of Virtual EAST System based on WebVR

J.Y. Xia<sup>1,2</sup>, B.J. Xiao<sup>1,2</sup>, Dan Li<sup>1</sup>, K.R. Wang<sup>1</sup>

<sup>1</sup> *Institute of Plasma Physics, Chinese Academy of Sciences, Hefei, Anhui, China*

<sup>2</sup> *University of Science and Technology of China, Hefei, Anhui, China*

E-mail of Corresponding Author: [jyxia@ipp.ac.cn](mailto:jyxia@ipp.ac.cn)

As with the EAST (Experimental Advanced Superconducting Tokamak) experimental data analyzed by more and more collaborators, the former virtual EAST system based on WebGL[1] needs improving to be more convenient for sharing and communication. The improved virtual EAST system is an open web-portal without plug-ins or third party components by using THREE.js. It offers a more highly-interactive interface for scientists to roam inside EAST device, view the complex structure, and acquire diagnostic meta data by user-friendly control panel. In order to enhance system's interactivity and user's immersion in 3D virtual scene, WebVR technology is used in new system, which provides support for exposing virtual reality devices. Moreover, the wiki system is integrated in the new system to display the information of EAST device and diagnostic systems, which providing collaborative modification and updating of the content. Compared the former system, the new system adds more visualization of models and experimental data. In this paper, we present the implementation details to optimize models and improve performance.

### References:

[1] XIA, J.Y., XIAO, B. J., LI, D., et al., Interactive WebGL-based 3D visualizations for EAST experiment. *Fusion Engineering & Design*, 112, 946-951( 2016)

## **P2/7/01: ITER CODAC Network Design**

G. Liu, P. Makijarvi and N. Pons

*ITER Organization, Route de Vinon-sur-Verdon, 13067 St Paul Lez Durance, France*

E-mail of Corresponding Author: [guoming.liu@iter.org](mailto:guoming.liu@iter.org)

At ITER, CODAC (Control, Data Access and Communication) is the conventional central control system responsible for operating the ITER facility. CODAC networks connect all plant systems to central system for different purposes. CODAC Networks comprise Plant Operation Network (PON), Time Communication Network (TCN), Synchronous Databus Network (SDN) and Data Archiving Network (DAN). The CODAC network infrastructure has been defined including network topology, backbone cable and space allocation network equipment in different ITER plant buildings.

This paper will present the design of the current network infrastructure and the four functional networks. This paper will also present some critical performances of the four networks which have been measured in the laboratory.

The CODAC networks are essential for the successful operation of ITER. The contiguous monitoring is crucial for the networks. This paper will describe the contiguous monitoring solution of the network performances and present some preliminary results.

## Notes

## Notes

## Notes